

## 滑台系列

## ETH Series

一般環境 / 螺桿式樣  
Standard/Ball Screw



精度  
±0.005 mm

應用例  
Application一般 / 螺桿式樣  
ETH Series一般 / 皮帶式樣  
ETB / M無塵 / 螺桿式樣  
GCH / ECH無塵 / 皮帶式樣  
ECB直交連結  
XYGT / XYTH / XYTB參考資料  
Reference

## CONTENTS

一般環境 / 螺桿式樣 Standard/Ball Screw Type

## 中型 MEDIUM

ETH13

低價格  
中荷重



本體寬幅 135mm  
Width  
最大行程 1050mm .....155  
Max. stroke  
最大荷重 70kg  
Max. payload

## 中型 MEDIUM

ETH14



本體寬幅 135mm  
Width  
最大行程 1050mm .....167  
Max. stroke  
最大荷重 110kg  
Max. payload

## 大型 LARGE

ETH17

高荷重



本體寬幅 170mm  
Width  
最大行程 1250mm .....179  
Max. stroke  
最大荷重 120kg  
Max. payload

## 大型 LARGE

ETH22

高荷重



本體寬幅 220mm  
Width  
最大行程 1500mm .....189  
Max. stroke  
最大荷重 150kg  
Max. payload

## 長行程系列 Long Stroke Ball Screw Actuator

## 大型 LARGE

ETH17M

高荷重



本體寬幅 170mm  
Width  
最大行程 2200mm .....195  
Max. stroke  
最大荷重 120kg  
Max. payload

## 大型 LARGE

ETH22M

高荷重



本體寬幅 220mm  
Width  
最大行程 2400mm .....205  
Max. stroke  
最大荷重 130kg  
Max. payload

# 滑台模組規格索引

## Spec Index of Electric Actuator

### ETH 標準螺桿滑台系列

#### ETH Ball Screw Actuator - Slider Type

使用環境 Environment	傳動方式 Driven Mode	仕樣 Specification	馬達容量 Motor Output (w)	本體寬幅 Width(mm)	位置重複精度 Repeatability(mm)	螺桿規格 (C7 級) Ball Screw Spec		最大可搬重量 Maximum Payload(kg)		最高速度 *1 Maximum Speed (mm/s)
						外徑 Outer Diameter(mm)	導程 Lead(mm)	水平使用 Horizontal	垂直使用 Vertical	
一般環境 Standard	滾珠螺桿 Ball screw	ETH13	200W	135	±0.005	16	5	70	17	250
							10	47	12	500
							20	24	6	1000
							32	13	-	1600
		ETH14	400W	135	±0.005	16	5	70	17	250
							10	47	12	500
							20	24	6	1000
							32	13	-	1600
		ETH14	200W	135	±0.005	16	5	95	27	250
							10	75	18	500
							20	35	7	1000
							32	15	-	1600
		ETH17	400W	135	±0.005	16	5	110	33	250
							10	88	22	500
							20	40	10	1000
							32	30	8	1600
		ETH17	400W	170	±0.005	20	5	120	40	250
							10	110	30	500
							20	75	14	1000
							40	22	7	2000
ETH22	750W	170	±0.005	20	5	120	50	250		
					10	120	40	500		
					20	83	25	1000		
					40	43	12	2000		
ETH22	750W	220	±0.005	20	25	5	150	55	250	
					25	10	150	45	500	
					25	25	105	20	1250	
					20	40	43	12	2000	

\*1: 最高速度 (MM/S) 是以伺服馬達最高轉速 3000RPM 為基準。

The highest speed is based on the maximum servo motor's rpm (3000).

\*2: 標準行程內的黑色數字, 代表該行程內可使用的最高安全速度。若超過此速度, 滑台可能有嚴重共振產生。

Written here is the standard stroke's maximum safe speed. If over this speed, it may casue serious vibration.

### 長行程系列

Long Stroke Ball Screw Actuator

使用環境 Environment	傳動方式 Driven Mode	仕樣 Specification	馬達容量 Motor Output (w)	本體寬幅 Width(mm)	位置重複精度 Repeatability(mm)	螺桿規格 (C7 級) Ball Screw Spec		最大可搬重量 Maximum Payload(kg)		最高速度 *1 Maximum Speed (mm/s)
						外徑 Outer Diameter(mm)	導程 Lead(mm)	水平使用 Horizontal	垂直使用 Vertical	
一般環境 Standard	滾珠螺桿 Ball screw	ETH17M	400W	170	±0.005	16	5	110	33	200
							10	90	22	400
							20	40	10	800
							32	30	8	1280
		ETH17M	750W	170	±0.005	16	5	120	40	200
							10	95	25	400
							20	50	15	800
							32	35	12	1280
		ETH22M	750W	220	±0.005	20	5	130	50	200
							10	130	40	400
							20	85	25	800
							40	43	12	1600

\*1: 最高速度 (MM/S) 是以伺服馬達最高轉速 2400RPM 為基準。

The highest speed is based on the maximum servo motor's rpm (2400).

免費服務專線：大陸 400-875-0009 台灣 0800-800-893  
 Toll-free Number China Taiwan

應用例  
Application

一般 / 螺桿仕様  
ETH Series

一般 / 皮帶仕様  
ETB / M

無塵 / 螺桿仕様  
GCH / ECH

無塵 / 皮帶仕様  
ECB

直交連結  
XYGT / XYTH / XYTB

參考資料  
Reference

標準行程及最高使用速度 *2																				代表速度 Speed										頁數 Page	
行程 Stroke	50	100	150	200	250	300	350	400	450	500	550	600	650	700	750	800	850	900	950	1000	1050	1100	1150	1200	1250	1300	1350	1400	1450	1500	
250																225	200	175	150	125	100										
500																450	400	350	300	250	200										
1000																900	800	700	600	500	400										
1600																1440	1280	1120	960	800	640										
250																225	200	175	150	125	100										
500																450	400	350	300	250	200										
1000																900	800	700	600	500	400										
1600																1440	1280	1120	960	800	640										
250																225	200	175	150	125	100										
500																450	400	350	300	250	200										
1000																900	800	700	600	500	400										
1600																1440	1280	1120	960	800	640										
250																225	200	175	150	125	100										
500																450	400	350	300	250	200										
1000																900	800	700	600	500	400										
1600																1440	1280	1120	960	800	640										
250																		225	200	175	150			175	150						
500																		450	400	350	300			350	300						
1000																		900	800	700	600			700	600						
2000																		1800	1600	1400	1200			1400	1200						
250																			225	200	175	150			150	125	100				
500																			450	400	350	300			300	250	200				
1000																			900	800	700	600			600	500	400				
2000																			1800	1600	1400	1200			1200	1000	800	600			

標準行程及最高使用速度 *2																				代表速度 Speed										頁數 Page
行程 Stroke	800	850	900	950	1000	1100	1200	1300	1400	1500	1600	1650	1700	1750	1800	1850	1900	1950	2000	2050	2100	2150	2200	2250	2300	2350	2400			
200															175			150					125							
400															350			300					250							
800															700			600					500							
1280															1120			960					800							
200															175			150					125							
400															350			300					250							
800															700			600					500							
1280															1120			960					800							
200																200							175			150				
400																400							350			300				
800																800							700			600				
1680																1680							1120			1200				

\*2: 標準行程內的黑色數字，代表該行程內可使用的最高安全速度。若超過此速度，滑台可能有嚴重共振產生。  
 Written here is the standard stroke's maximum safe speed. If over this speed, it may casue serious vibration.

# ETH13 單軸 / 1-axis

▶ 螺桿驅動  
Ball Screw Drive



精度 ↑  
±0.005 mm

此圖僅供參考，出貨規格詳見尺寸圖面  
The picture is just for the reference. Please check the actual dimensions on the drawing.

- 最大行程 Maximum Stroke **1050mm**
- 最高速度 Maximum Speed **1600mm/s**
- 馬達容量 Motor output **200W**
- 滾珠螺桿 Ball Screw **Ø 16mm**
- 直線滑軌 Linear Guide **15X12.5-2 支**

## 型號表示方式 Ordering Method

# ETH13 - L5 - 50 - BC - M20B - C 4 - 0001

本體型號  
Model

特注式樣  
Special Order No.

行程  
Stroke  
50-1050mm  
50間隔 50 mm Pitch

馬達位置  
Motor Position

M	馬達直結 Motor Hidden In
BC	馬達外露 Motor Exposed
BL	馬達左折 Motor Left Side
BR	馬達右折 Motor Right Side
BM	馬達下折 Motor Bottom Side

馬達廠牌  
Motor Brand

M	三菱 Mitsubishi	10	-	B
P	國際 Panasonic	20	200W	
Y	安川 Yaskawa	40	-	
T	台達 Delta	75	-	

\*若無煞車則不表示。\*If No Brake, No Description.

原點感應器  
Home Sensor

內置型 In Side	
A	馬達側 Motor Side
B	反馬達側 Opposite Motor Side
外掛型 Out Side	
C	馬達側 Motor Side
D	反馬達側 Opposite Motor Side
	無 SENSOR No Sensor
E	無 SENSOR No Sensor

端點極限感應器  
Limit Sensor

內置型 In Side	
1	1只 1 Pc
2	2只 2 Pc
外掛型 Out Side	
3	1只 1 Pc
4	2只 2 Pc
	無 SENSOR No Sensor
5	無 SENSOR No Sensor

螺桿導程  
Ball Screw Lead

5	5mm
10	10mm
20	20mm
32	32mm

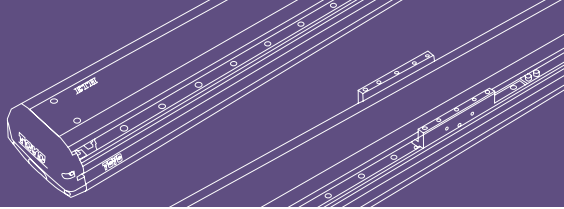

應用例  
Application

一般 / 螺桿仕様  
ETH Series

一般 / 皮帶仕様  
ETB / M

無塵 / 螺桿仕様  
GCH / ECH

無塵 / 皮帶仕様  
ECB

直交連結  
XYGT / XYTH / XYTB

參考資料  
Reference

基本仕様 Specification

規格 Spec	位置重複精度 Repeatability (mm)	±0.005				
	螺桿導程 Ball Screw Lead (mm)	5	10	20	32	
	最高速度 Maximum Speed (mm/s) ※1	250	500	1000	1600	
	最大可搬重量 Maximum Payload	水平使用 Horizontal (kg)	70	47	24	13
		垂直使用 Vertical (kg)	17	12	6	-
	定格推力 Rated Thrust (N)	683 341 174 107				
部品 Parts	標準行程 Stroke Pitch (mm) ※2	50-1050mm/50 間隔 50 mm Pitch				
	AC 伺服馬達容量 AC Servo Motor Output (W)	200				
	滾珠螺桿外徑 Ball Screw Ø (mm)	C7Ø16				
	高剛性直線滑軌, High Rigidity Linear Guide (mm)	W15XH12.5				
	連軸器 Coupling (mm)	10X14/11 (註1)				
	原點感應器 Home Sensor	外掛 Outside	EE-SX672(NPN)			
內置 Built-In		EE-SX674(NPN)				

※1 馬達加減速設定 0.2 秒。  
Acceleration and deceleration value is set 0.2 second.  
※2 行程超過 750 時，會產生螺桿偏擺，此時請將速度調降。  
When the stroke is over 750mm, the run-out of the ballscrew will occur. We recommend to low down the working speed under this circumstances.  
註1: 使用 Panasonic 200W 馬達時，馬達軸心為 Ø11；其他廠牌，馬達軸心為 Ø14。  
Motor (200W) Shaft Diameter: Panasonic: 11mm; Other: 14mm.

感應器接線圖 < 原點及端點 > Sensor Layout

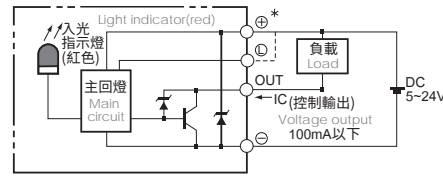

容許負載力距表 Allowable Overhang

水平安裝 Horizontal Installation				壁掛安裝 Wall Installation				垂直安裝 Vertical Installation			
導程 Lead	A	B	C	導程 Lead	A	B	C	導程 Lead	A	C	
5	40kg	795	63	225	30kg	310	88	1066	5kg	580	580
	55kg	558	43	155	50kg	172	49	620	11kg	264	264
	70kg	422	32	115	70kg	115	32	422	17kg	170	170
10	25kg	588	95	276	20kg	351	122	743	4kg	644	644
	35kg	410	65	190	30kg	225	78	484	8kg	322	322
	47kg	295	46	135	47kg	135	46	294	12kg	215	215
20	6kg	1068	355	710	5kg	852	428	1227	3kg	667	667
	15kg	416	136	275	12kg	345	173	522	6kg	335	335
	24kg	252	81	166	24kg	166	81	253	-	-	-
32	7kg	385	205	298	6kg	350	240	453	-	-	-
	13kg	204	106	156	13kg	155	106	204	-	-	-
	-	-	-	-	-	-	-	-	-	-	-

靜態容許負載慣量 Static Loading Moment

MY	MP	MR
174	175	153

\* 力距表所表示的數據，代表重心。  
The torque value in the chart indicate the center of gravity.  
\* 符合型錄規範的正常使用下，保證壽命為 10000 公里。  
Operation life is 10,000km when the product is using under the specified conditions.  
\* 倒吊使用無法套用標準規範，如有需求請洽詢我司業務。  
Data information is not for ceiling-mount inverse use.  
Contact us for the details if you want to apply ceiling-mount inverse usage.

搭配伺服馬達一覽表 Suitable Motor Brand

廠牌 Brand	馬達記號 Mark	煞車有無 Brake	馬達容量 Watt	電源電壓 AC-Voltage	伺服馬達型號 Motor Model	驅動器型號 Driver Model
三菱 Mitsubishi	M	無煞車 (水平仕様) No Brake (Horizontal Type)	200	220	HG-KR23	MR-J4-20A
		有煞車 (垂直仕様) With Brake (Vertical Type)	200	220	HG-KR23B	MR-J4-20A
國際 Panasonic	P	無煞車 (水平仕様) No Brake (Horizontal Type)	200	220	MHMD022G1U	MADHT1507
		有煞車 (垂直仕様) With Brake (Vertical Type)	200	220	MHMD022G1V	MADHT1507
台達 Delta	T	無煞車 (水平仕様) No Brake (Horizontal Type)	200	220	ECMA-C20602ES	ASD-B20221-B
		有煞車 (垂直仕様) With Brake (Vertical Type)	200	220	ECMA-C20602FS	ASD-B20221-B

單軸  
1 axis  
ETH

ETH13

ETH14

ETH17

ETH22

ETH17M

ETH22M

## 馬達直結 / 馬達外露

Motor Hidden In / Motor Exposed

### M 馬達直結 Motor Hidden In



Download CAD data at [www.toyrobot.com](http://www.toyrobot.com)

單位 Unit : mm

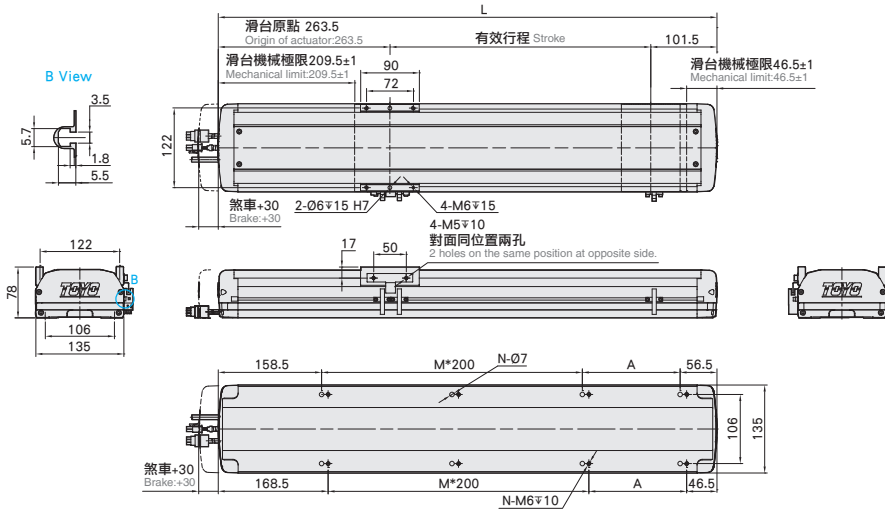

有效行程 Stroke	50	100	150	200	250	300	350	400	450	500	550	600	650	700	750	800	850	900	950	1000	1050
L	415	465	515	565	615	665	715	765	815	865	915	965	1015	1065	1115	1165	1215	1265	1315	1365	1415
A	200	50	100	150	200	50	100	150	200	50	100	150	200	50	100	150	200	50	100	150	200
M	0	1	1	1	1	2	2	2	2	3	3	3	3	4	4	4	4	5	5	5	5
N	4	6	6	6	6	8	8	8	8	10	10	10	10	12	12	12	12	14	14	14	14
KG	8.3	8.86	9.42	9.98	10.54	11.1	11.66	12.22	12.78	13.34	13.9	14.46	15.02	15.58	16.14	16.7	17.26	17.82	18.38	18.94	19.5

### BC 馬達外露 Motor Exposed



Download CAD data at [www.toyrobot.com](http://www.toyrobot.com)

單位 Unit : mm

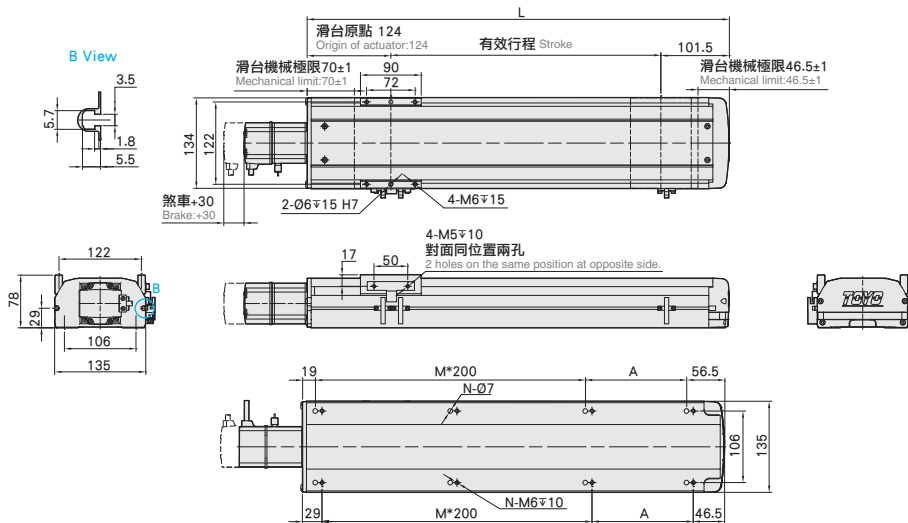

有效行程 Stroke	50	100	150	200	250	300	350	400	450	500	550	600	650	700	750	800	850	900	950	1000	1050
L	275.5	325.5	375.5	425.5	475.5	525.5	575.5	625.5	675.5	725.5	775.5	825.5	875.5	925.5	975.5	1025.5	1075.5	1125.5	1175.5	1225.5	1275.5
A	200	50	100	150	200	50	100	150	200	50	100	150	200	50	100	150	200	50	100	150	200
M	0	1	1	1	1	2	2	2	2	3	3	3	3	4	4	4	4	5	5	5	5
N	4	6	6	6	6	8	8	8	8	10	10	10	10	12	12	12	12	14	14	14	14
KG	7.4	7.96	8.52	9.08	9.64	10.2	10.76	11.32	11.88	12.44	13	13.56	14.12	14.68	15.24	15.8	16.36	16.92	17.48	18.04	18.6

# 馬達左折 / 馬達右折

## Motor Left Side / Motor Right Side

**BL 馬達左折 Motor Left Side**   [Download CAD data at www.toyorobot.com](http://www.toyorobot.com)

單位 Unit : mm

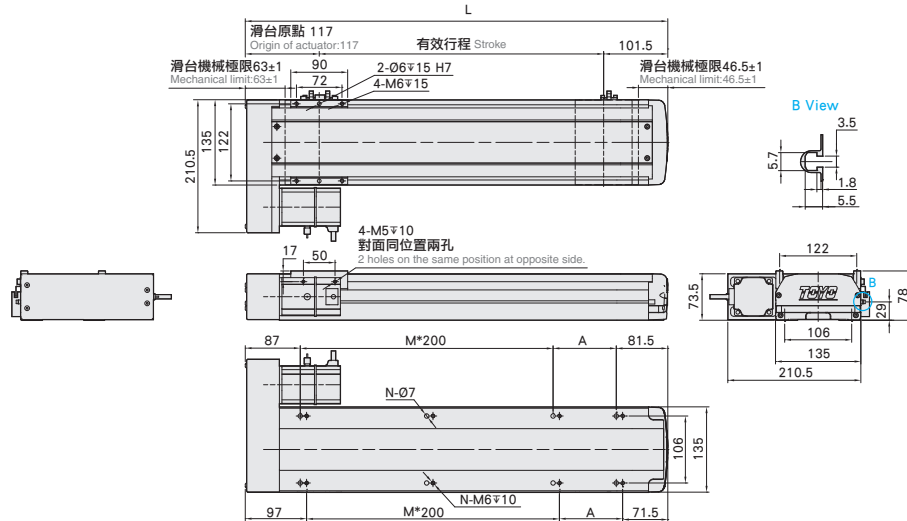

有效行程 Stroke	50	100	150	200	250	300	350	400	450	500	550	600	650	700	750	800	850	900	950	1000	1050
L	268.5	318.5	368.5	418.5	468.5	518.5	568.5	618.5	668.5	718.5	768.5	818.5	868.5	918.5	968.5	1018.5	1068.5	1118.5	1168.5	1218.5	1268.5
A	100	150	200	50	100	150	200	50	100	150	200	50	100	150	200	50	100	150	200	50	100
M	0	0	0	1	1	1	1	2	2	2	2	3	3	3	3	4	4	4	4	5	5
N	4	4	4	6	6	6	6	8	8	8	8	10	10	10	10	12	12	12	12	14	14
KG	7.94	8.5	9.06	9.62	10.18	10.74	11.3	11.86	12.42	12.98	13.54	14.1	14.66	15.22	15.78	16.34	16.9	17.46	18.02	18.58	19.14

**BR 馬達右折 Motor Right Side**   [Download CAD data at www.toyorobot.com](http://www.toyorobot.com)

單位 Unit : mm

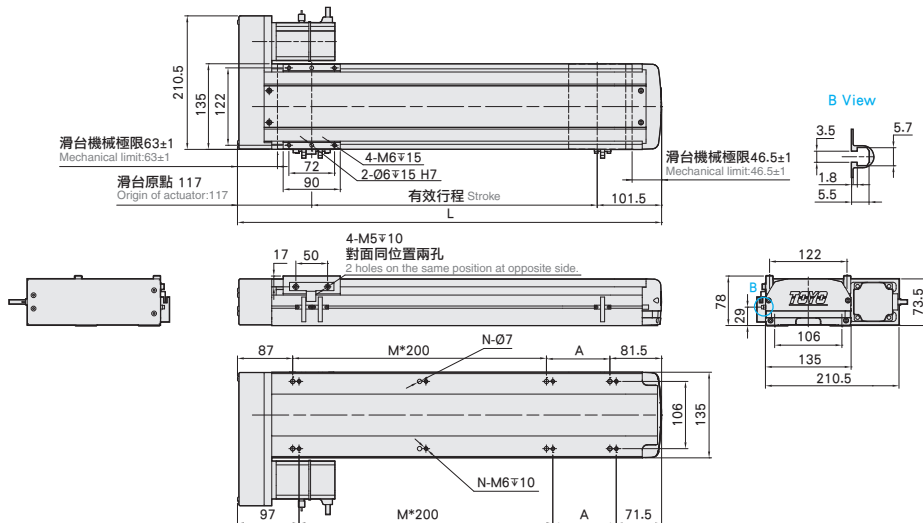

有效行程 Stroke	50	100	150	200	250	300	350	400	450	500	550	600	650	700	750	800	850	900	950	1000	1050
L	268.5	318.5	368.5	418.5	468.5	518.5	568.5	618.5	668.5	718.5	768.5	818.5	868.5	918.5	968.5	1018.5	1068.5	1118.5	1168.5	1218.5	1268.5
A	100	150	200	50	100	150	200	50	100	150	200	50	100	150	200	50	100	150	200	50	100
M	0	0	0	1	1	1	1	2	2	2	2	3	3	3	3	4	4	4	4	5	5
N	4	4	4	6	6	6	6	8	8	8	8	10	10	10	10	12	12	12	12	14	14
KG	7.94	8.5	9.06	9.62	10.18	10.74	11.3	11.86	12.42	12.98	13.54	14.1	14.66	15.22	15.78	16.34	16.9	17.46	18.02	18.58	19.14

應用例  
Application

一般 / 螺桿仕樣  
ETH Series

一般 / 皮帶仕樣  
ETB / M

無塵 / 螺桿仕樣  
GCH / ECH

無塵 / 皮帶仕樣  
ECB

直交連結  
XYGT / XYTH / XYTB

參考資料  
Reference

單軸  
1 axis  
ETH

ETH13

ETH14

ETH17

ETH22

ETH17M

ETH22M

## 馬達下折

### Motor Bottom Side

單位 Unit : mm

BM 馬達下折 Motor Bottom Side   [Download CAD data at www.toyorobot.com](http://www.toyorobot.com)

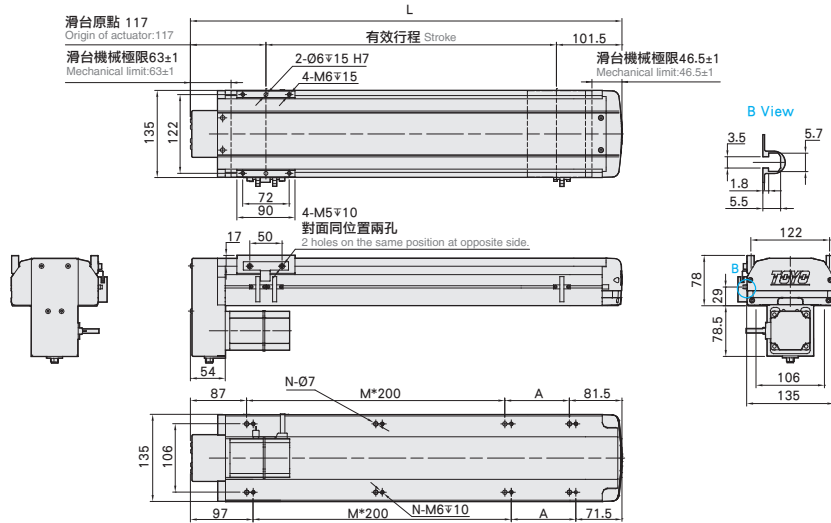

有效行程 Stroke	50	100	150	200	250	300	350	400	450	500	550	600	650	700	750	800	850	900	950	1000	1050
L	268.5	318.5	368.5	418.5	468.5	518.5	568.5	618.5	668.5	718.5	768.5	818.5	868.5	918.5	968.5	1018.5	1068.5	1118.5	1168.5	1218.5	1268.5
A	100	150	200	50	100	150	200	50	100	150	200	50	100	150	200	50	100	150	200	50	100
M	0	0	0	1	1	1	1	2	2	2	2	3	3	3	3	4	4	4	4	5	5
N	4	4	4	6	6	6	6	8	8	8	8	10	10	10	10	12	12	12	12	14	14
KG	7.94	8.5	9.06	9.62	10.18	10.74	11.3	11.86	12.42	12.98	13.54	14.1	14.66	15.22	15.78	16.34	16.9	17.46	18.02	18.58	19.14



免費服務專線：大陸 400-875-0009 台灣 0800-800-893  
Toll-free Number China Taiwan

應用例  
Application

一般 / 螺桿仕様  
ETH Series

一般 / 皮帶仕様  
ETB / M

無塵 / 螺桿仕様  
GCH / ECH

無塵 / 皮帶仕様  
ECB

直交連結  
XYGT / XYTH / XYTB

參考資料  
Reference

單軸  
1 axis  
**ETH**

ETH13

ETH14

ETH17

ETH22

ETH17M

ETH22M

# MEMO

# ETH13 單軸 / 1-axis

▶ 螺桿驅動  
Ball Screw Drive



精度 ↑  
±0.005 mm

此圖僅供參考，出貨規格詳見尺寸圖面  
The picture is just for the reference. Please check the actual dimensions on the drawing.

最大行程 Maximum Stroke	1050mm	最高速度 Maximum Speed	1600mm/s	馬達容量 Motor output	400W	滾珠螺桿 Ball Screw	Ø 16mm	直線滑軌 Linear Guide	15X12.5-2 支
------------------------	--------	-----------------------	----------	----------------------	------	--------------------	--------	----------------------	-------------

## 型號表示方式 Ordering Method

# ETH13 - L5 - 50 - BC - M40B - C 4 - 0001

本體型號  
Model

行程  
Stroke  
50-1050mm  
50間隔 50 mm Pitch

特注式樣  
Special Order No.

螺桿導程  
Ball Screw Lead

5	5mm
10	10mm
20	20mm
32	32mm

馬達位置  
Motor Position

M	馬達直結 Motor Hidden In
BC	馬達外露 Motor Exposed
BL	馬達左折 Motor Left Side
BR	馬達右折 Motor Right Side
BM	馬達下折 Motor Bottom Side

馬達廠牌  
Motor Brand

M	三菱 Mitsubishi	10	-	B
P	國際 Panasonic	20	-	
Y	安川 Yaskawa	40	400W	
T	台達 Delta	75	-	

\*若無煞車則不表示。\*If No Brake, No Description.

原點感應器  
Home Sensor

內置型 In Side	
A	馬達側 Motor Side
B	反馬達側 Opposite Motor Side
外掛型 Out Side	
C	馬達側 Motor Side
D	反馬達側 Opposite Motor Side
	無 SENSOR No Sensor
E	無 SENSOR No Sensor

端點極限感應器  
Limit Sensor

內置型 In Side	
1	1只 1 Pc
2	2只 2 Pc
外掛型 Out Side	
3	1只 1 Pc
4	2只 2 Pc
	無 SENSOR No Sensor
5	無 SENSOR No Sensor

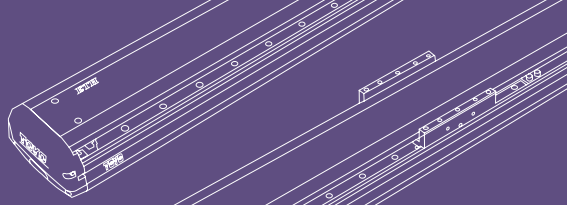

應用例  
Application

一般 / 螺桿仕様  
ETH Series

一般 / 皮帶仕様  
ETB / M

無塵 / 螺桿仕様  
GCH / ECH

無塵 / 皮帶仕様  
ECB

直交連結  
XYGT / XYTH / XYTB

參考資料  
Reference

基本仕様 Specification

規格 Spec	位置重複精度 Repeatability (mm)	±0.005				
	螺桿導程 Ball Screw Lead (mm)	5	10	20	32	
	最高速度 Maximum Speed (mm/s)*1	250	500	1000	1600	
	最大可搬重量 Maximum Payload	水平使用 Horizontal (kg)	70	47	24	13
		垂直使用 Vertical (kg)	17	12	6	-
	定格推力 Rated Thrust (N)	1388 694 433 347				
部品 Parts	標準行程 Stroke Pitch (mm)*2	50-1050mm/50 間隔 50 mm Pitch				
	AC 伺服馬達容量 AC Servo Motor Output (W)	400				
	滾珠螺桿外徑 Ball Screw Ø (mm)	C7Ø16				
	高剛性直線滑軌, High Rigidity Linear Guide (mm)	W15XH12.5				
	連軸器 Coupling (mm)	10X14/1 <sup>(註1)</sup>				
	原點感應器 Home Sensor	外掛 Outside	EE-SX672(NPN)			
內置 Built-In		EE-SX674(NPN)				

\*1 馬達加減速設定 0.2 秒。  
Acceleration and deceleration value is set 0.2 second.  
\*2 行程超過 750 時，會產生螺桿偏擺，此時請將速度調降。  
When the stroke is over 750mm, the run-out of the ballscrew will occur. We recommend to low down the working speed under this circumstances.  
註 1: 使用 Panasonic 200W 馬達時，馬達軸心為 Ø11；其他廠牌，馬達軸心為 Ø14。  
Motor (200W) Shaft Diameter: Panasonic: 11mm; Other: 14mm.

感應器接線圖 < 原點及端點 > Sensor Layout

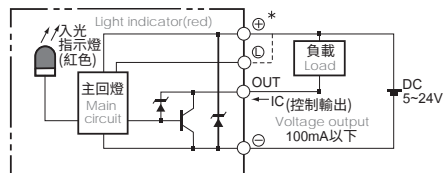

容許負載力距表 Allowable Overhang

水平安裝 Horizontal Installation				壁掛安裝 Wall Installation				垂直安裝 Vertical Installation			
導程 Lead	A	B	C	導程 Lead	A	B	C	導程 Lead	A	C	
5	40kg	795	63	225	30kg	310	88	1066	5kg	580	580
	55kg	558	43	155	50kg	172	49	620	11kg	264	264
	70kg	422	32	115	70kg	115	32	422	17kg	170	170
10	25kg	588	95	276	20kg	351	122	743	4kg	644	644
	35kg	410	65	190	30kg	225	78	484	8kg	322	322
	47kg	295	46	135	47kg	135	46	294	12kg	215	215
20	6kg	1068	355	710	5kg	852	428	1227	3kg	667	667
	15kg	416	136	275	12kg	345	173	522	6kg	335	335
	24kg	252	81	166	24kg	166	81	253	-	-	-
32	7kg	385	205	298	6kg	350	240	453	-	-	-
	13kg	204	106	156	13kg	155	106	204	-	-	-
	-	-	-	-	-	-	-	-	-	-	-

靜態容許負載價量 Static Loading Moment

MY	MP	MR
174	175	153

\* 力距表所表示的數據，代表重心。  
The torque value in the chart indicate the center of gravity.  
\* 符合型錄規範的正常使用下，保證壽命為 10000 公里。  
Operation life is 10,000km when the product is using under the specified conditions.  
\* 倒吊使用無法套用標準規範，如有需求請洽詢我司業務。  
Data information is not for ceiling-mount inverse use.  
Contact us for the details if you want to apply ceiling-mount inverse usage.

搭配伺服馬達一覽表 Suitable Motor Brand

廠牌 Brand	馬達記號 Mark	煞車有無 Brake	馬達容量 Watt	電源電壓 AC-Voltage	伺服馬達型號 Motor Model	驅動器型號 Driver Model
三菱 Mitsubishi	M	無煞車 (水平仕様) No Brake (Horizontal Type)	400	220	HG-KR43	MR-J4-40A
		有煞車 (垂直仕様) With Brake (Vertical Type)	400	220	HG-KR43B	MR-J4-40A
國際 Panasonic	P	無煞車 (水平仕様) No Brake (Horizontal Type)	400	220	MHMD042G1U	MBDHT2510
		有煞車 (垂直仕様) With Brake (Vertical Type)	400	220	MHMD042G1V	MBDHT2510
台達 Delta	T	無煞車 (水平仕様) No Brake (Horizontal Type)	400	220	ECMA-C20604ES	ASD-B20421-B
		有煞車 (垂直仕様) With Brake (Vertical Type)	400	220	ECMA-C20604FS	ASD-B20421-B

單軸  
1 axis  
ETH

ETH13

ETH14

ETH17

ETH22

ETH17M

ETH22M

## 馬達直結 / 馬達外露

Motor Hidden In / Motor Exposed

### M 馬達直結 Motor Hidden In



Download CAD data at [www.toyorobot.com](http://www.toyorobot.com)

單位 Unit : mm

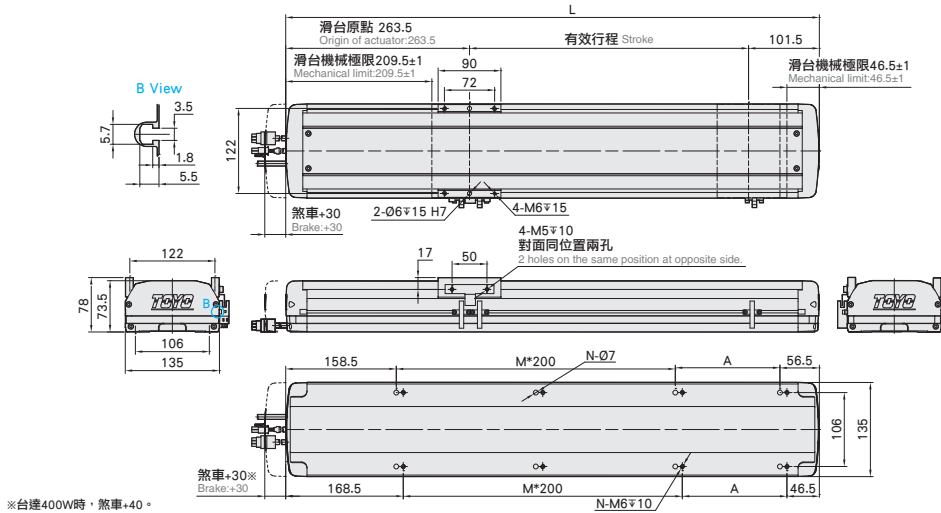

有效行程 Stroke	50	100	150	200	250	300	350	400	450	500	550	600	650	700	750	800	850	900	950	1000	1050
L	415	465	515	565	615	665	715	765	815	865	915	965	1015	1065	1115	1165	1215	1265	1315	1365	1415
A	200	50	100	150	200	50	100	150	200	50	100	150	200	50	100	150	200	50	100	150	200
M	0	1	1	1	1	2	2	2	2	3	3	3	3	4	4	4	4	5	5	5	5
N	4	6	6	6	6	8	8	8	8	10	10	10	10	12	12	12	12	14	14	14	14
KG	8.3	8.86	9.42	9.98	10.54	11.1	11.66	12.22	12.78	13.34	13.9	14.46	15.02	15.58	16.14	16.7	17.26	17.82	18.38	18.94	19.5

### BC 馬達外露 Motor Exposed



Download CAD data at [www.toyorobot.com](http://www.toyorobot.com)

單位 Unit : mm

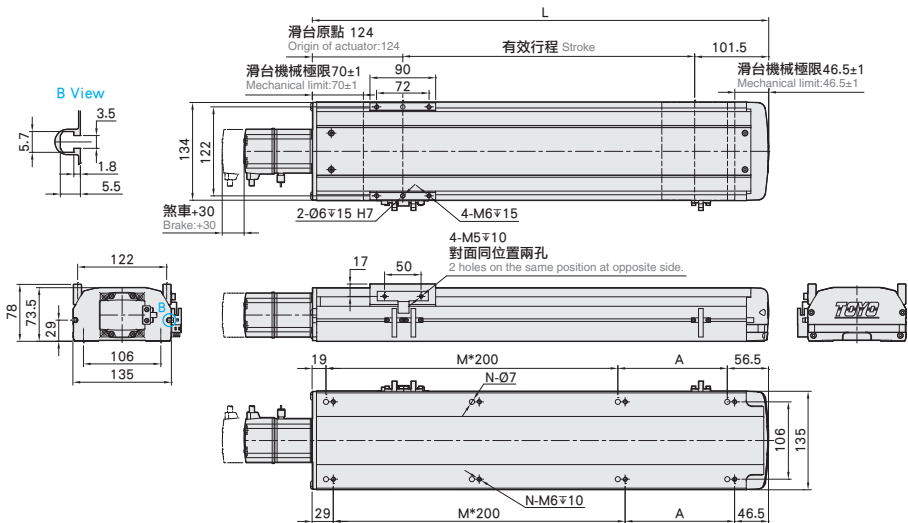

有效行程 Stroke	50	100	150	200	250	300	350	400	450	500	550	600	650	700	750	800	850	900	950	1000	1050
L	275.5	325.5	375.5	425.5	475.5	525.5	575.5	625.5	675.5	725.5	775.5	825.5	875.5	925.5	975.5	1025.5	1075.5	1125.5	1175.5	1225.5	1275.5
A	200	50	100	150	200	50	100	150	200	50	100	150	200	50	100	150	200	50	100	150	200
M	0	1	1	1	1	2	2	2	2	3	3	3	3	4	4	4	4	5	5	5	5
N	4	6	6	6	6	8	8	8	8	10	10	10	10	12	12	12	12	14	14	14	14
KG	7.4	7.96	8.52	9.08	9.64	10.2	10.76	11.32	11.88	12.44	13	13.56	14.12	14.68	15.24	15.8	16.36	16.92	17.48	18.04	18.6

# 馬達左折 / 馬達右折

## Motor Left Side / Motor Right Side

**BL 馬達左折 Motor Left Side**   [Download CAD data at www.toyorobot.com](http://www.toyorobot.com)

單位 Unit : mm

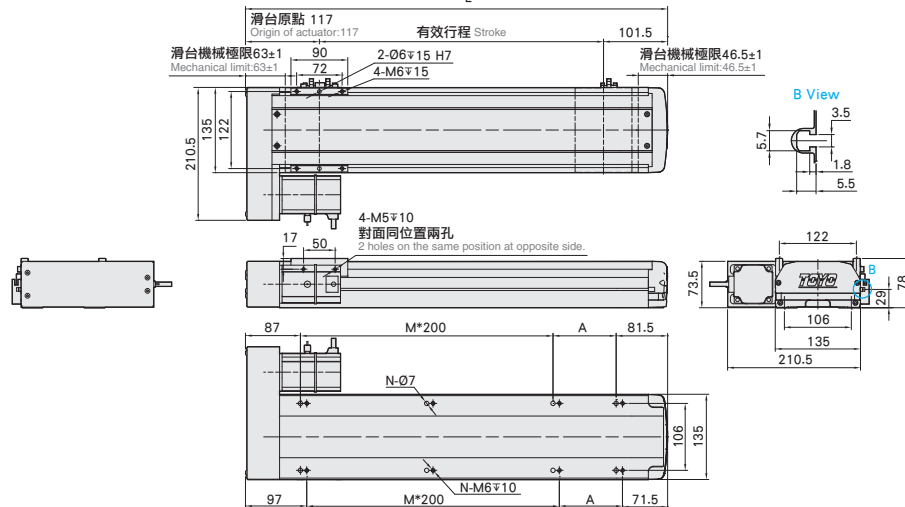

有效行程 Stroke	50	100	150	200	250	300	350	400	450	500	550	600	650	700	750	800	850	900	950	1000	1050
L	268.5	318.5	368.5	418.5	468.5	518.5	568.5	618.5	668.5	718.5	768.5	818.5	868.5	918.5	968.5	1018.5	1068.5	1118.5	1168.5	1218.5	1268.5
A	100	150	200	50	100	150	200	50	100	150	200	50	100	150	200	50	100	150	200	50	100
M	0	0	0	1	1	1	1	2	2	2	2	3	3	3	3	4	4	4	4	5	5
N	4	4	4	6	6	6	6	8	8	8	8	10	10	10	10	12	12	12	12	14	14
KG	7.94	8.5	9.06	9.62	10.18	10.74	11.3	11.86	12.42	12.98	13.54	14.1	14.66	15.22	15.78	16.34	16.9	17.46	18.02	18.58	19.14

**BR 馬達右折 Motor Right Side**   [Download CAD data at www.toyorobot.com](http://www.toyorobot.com)

單位 Unit : mm

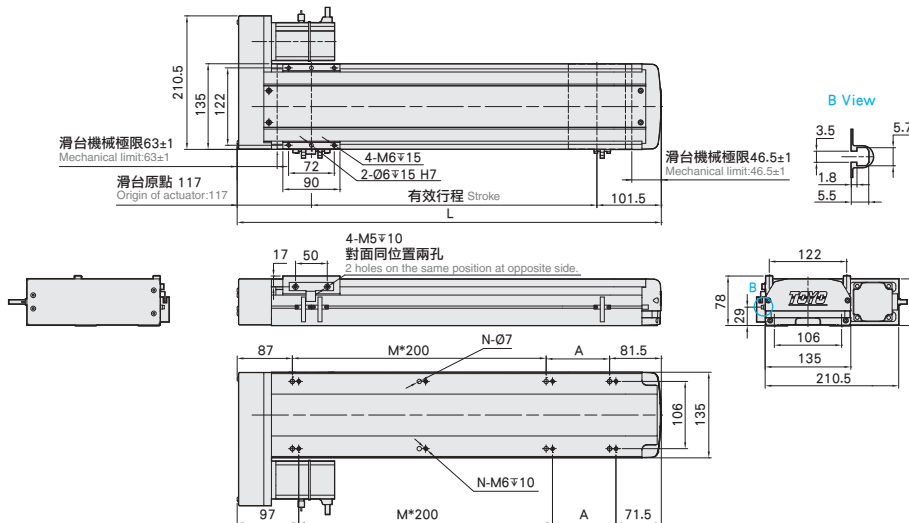

有效行程 Stroke	50	100	150	200	250	300	350	400	450	500	550	600	650	700	750	800	850	900	950	1000	1050
L	268.5	318.5	368.5	418.5	468.5	518.5	568.5	618.5	668.5	718.5	768.5	818.5	868.5	918.5	968.5	1018.5	1068.5	1118.5	1168.5	1218.5	1268.5
A	100	150	200	50	100	150	200	50	100	150	200	50	100	150	200	50	100	150	200	50	100
M	0	0	0	1	1	1	1	2	2	2	2	3	3	3	3	4	4	4	4	5	5
N	4	4	4	6	6	6	6	8	8	8	8	10	10	10	10	12	12	12	12	14	14
KG	7.94	8.5	9.06	9.62	10.18	10.74	11.3	11.86	12.42	12.98	13.54	14.1	14.66	15.22	15.78	16.34	16.9	17.46	18.02	18.58	19.14

應用例  
Application

一般 / 螺桿仕様  
ETH Series

一般 / 皮帶仕様  
ETB / M

無塵 / 螺桿仕様  
GCH / ECH

無塵 / 皮帶仕様  
ECB

直交連結  
XYGT / XYTH / XYTB

參考資料  
Reference

單軸  
1 axis  
ETH

ETH13

ETH14

ETH17

ETH22

ETH17M

ETH22M

## 馬達下折

### Motor Bottom Side

單位 Unit : mm

BM 馬達下折 Motor Bottom Side   [Download CAD data at www.toyorobot.com](http://www.toyorobot.com)

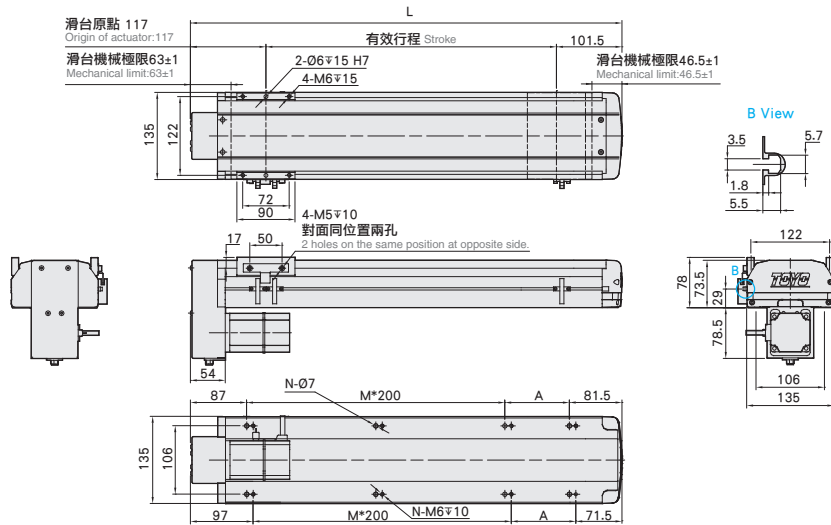

有效行程 Stroke	50	100	150	200	250	300	350	400	450	500	550	600	650	700	750	800	850	900	950	1000	1050
L	268.5	318.5	368.5	418.5	468.5	518.5	568.5	618.5	668.5	718.5	768.5	818.5	868.5	918.5	968.5	1018.5	1068.5	1118.5	1168.5	1218.5	1268.5
A	100	150	200	50	100	150	200	50	100	150	200	50	100	150	200	50	100	150	200	50	100
M	0	0	0	1	1	1	1	2	2	2	2	3	3	3	3	4	4	4	4	5	5
N	4	4	4	6	6	6	6	8	8	8	8	10	10	10	10	12	12	12	12	14	14
KG	7.94	8.5	9.06	9.62	10.18	10.74	11.3	11.86	12.42	12.98	13.54	14.1	14.66	15.22	15.78	16.34	16.9	17.46	18.02	18.58	19.14

免費服務專線：大陸 400-875-0009 台灣 0800-800-893  
Toll-free Number China Taiwan

應用例  
Application

一般 / 標準仕様  
ETH Series

一般 / 皮帶仕様  
ETB / M

無塵 / 標準仕様  
GCH / ECH

無塵 / 皮帶仕様  
ECB

直交連結  
XYGT / XYTH / XYTB

參考資料  
Reference

單軸  
1 axis  
**ETH**

ETH13

ETH14

ETH17

ETH22

ETH17M

ETH22M

# MEMO

# ETH14 單軸 / 1-axis

▶ 螺桿驅動  
Ball Screw Drive



精度 ↑  
±0.005 mm

此圖僅供參考，出貨規格詳見尺寸圖面  
The picture is just for the reference. Please check the actual dimensions on the drawing.

- 最大行程 Maximum Stroke **1050mm**
- 最高速度 Maximum Speed **1600mm/s**
- 馬達容量 Motor output **200W**
- 滾珠螺桿 Ball Screw **Ø 16mm**
- 直線滑軌 Linear Guide **15X12.5-2 支**

## 型號表示方式 Ordering Method

# ETH14 - L 5 - 50 - M - M20B - C 4 - 0001

本體型號  
Model

特注式樣  
Special Order No.

行程  
Stroke  
50-1050mm  
50間隔 50 mm Pitch

馬達位置  
Motor Position

M	馬達直結 Motor Hidden In
BC	馬達外露 Motor Exposed
BL	馬達左折 Motor Left Side
BR	馬達右折 Motor Right Side
BM	馬達下折 Motor Bottom Side

馬達廠牌  
Motor Brand

M	三菱 Mitsubishi	10	-	B
P	國際 Panasonic	20	200W	
Y	安川 Yaskawa	40	-	
T	台達 Delta	75	-	

\*若無煞車則不表示。\* If No Brake, No Description.

原點感應器  
Home Sensor

內置型 In Side	
A	馬達側 Motor Side
B	反馬達側 Opposite Motor Side
外掛型 Out Side	
C	馬達側 Motor Side
D	反馬達側 Opposite Motor Side
	無 SENSOR No Sensor
E	無 SENSOR No Sensor

端點極限感應器  
Limit Sensor

內置型 In Side	
1	1只 1 Pc
2	2只 2 Pc
外掛型 Out Side	
3	1只 1 Pc
4	2只 2 Pc
	無 SENSOR No Sensor
5	無 SENSOR No Sensor

螺桿導程  
Ball Screw Lead

5	05mm
10	10mm
20	20mm
32	32mm



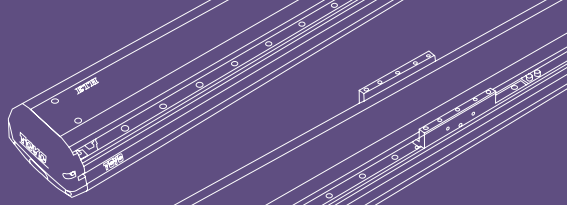

基本仕様 Specification

規格 Spec	位置重複精度 Repeatability (mm)	±0.005				
	螺桿導程 Ball Screw Lead (mm)	5	10	20	32	
	最高速度 Maximum Speed (mm/s) ※1	250	500	1000	1600	
	最大可搬重量 Maximum Payload	水平使用 Horizontal (kg)	95	75	35	15
		垂直使用 Vertical (kg)	27	18	7	-
定格推力 Rated Thrust (N)	683 341 174 107					
部品 Parts	標準行程 Stroke Pitch (mm) ※2	50-1050mm/50 間隔 50 mm Pitch				
	AC 伺服馬達容量 AC Servo Motor Output (W)	200				
	滾珠螺桿外徑 Ball Screw Ø (mm)	C7Ø16				
	高剛性直線滑軌, High Rigidity Linear Guide (mm)	W15XH12.5				
	連軸器 Coupling (mm)	10X14/11 <sup>(註1)</sup>				
	原點感應器 Home Sensor	外掛 Outside	EE-SX672(NPN)			
內置 Built-In		EE-SX674(NPN)				

※1 馬達加減速設定 0.2 秒。  
Acceleration and deceleration value is set 0.2 second.  
※2 行程超過 750 時，會產生螺桿偏擺，此時請將速度調降。  
over 750mm, the run-out of the ballscrew will occur. We recommend to low down the working speed under this circumstances.  
註 1: 使用 Panasonic 200W 馬達時，馬達軸心為 Ø11；其他廠牌，馬達軸心為 Ø14。  
Motor (200W) Shaft Diameter: Panasonic: 11mm; Other: 14mm.

感應器接線圖 < 原點及端點 > Sensor Layout

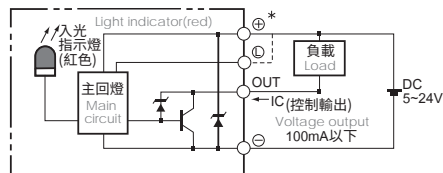

容許負載力距表 Allowable Overhang

水平安裝 Horizontal Installation				壁掛安裝 Wall Installation				垂直安裝 Vertical Installation			
導程 Lead	A	B	C	導程 Lead	A	B	C	導程 Lead	A	C	
5	60kg	2512	242	232	55kg	257	269	2883	15kg	1118	1118
	80kg	1811	172	164	75kg	178	186	2000	22kg	770	770
	95kg	1537	138	133	95kg	133	138	1537	27kg	626	626
10	30kg	2727	470	430	35kg	363	395	2368	10kg	1500	1500
	50kg	1577	266	242	55kg	218	238	1445	14kg	1072	1072
	75kg	1004	164	150	75kg	150	164	1004	18kg	833	833
20	10kg	2304	1222	1028	12kg	854	1019	2552	4kg	2980	2980
	22kg	1443	540	451	20kg	500	596	1588	7kg	1700	1700
	35kg	1005	324	271	35kg	271	324	1005	-	-	-
32	10kg	1555	840	623	8kg	787	1060	1980	-	-	-
	15kg	1033	545	405	15kg	405	545	1033	-	-	-
	-	-	-	-	-	-	-	-	-	-	-

靜態容許負載價量 Static Loading Moment

MY	MP	MR
551	552	485

\* 力距表所表示的數據，代表重心。  
The torque value in the chart indicate the center of gravity.  
\* 符合型錄規範的正常使用下，保證壽命為 10000 公里。  
Operation life is 10,000km when the product is using under the specified conditions.  
\* 倒吊使用無法套用標準規範，如有需求請洽詢我司業務。  
Data information is not for ceiling-mount inverse use.  
Contact us for the details if you want to apply ceiling-mount inverse usage.

搭配伺服馬達一覽表 Suitable Motor Brand

廠牌 Brand	馬達記號 Mark	煞車有無 Brake	馬達容量 Watt	電源電壓 AC-Voltage	伺服馬達型號 Motor Model	驅動器型號 Driver Model
三菱 Mitsubishi	M	無煞車 (水平仕様) No Brake (Horizontal Type)	200	220	HG-KR23	MR-J4-20A
		有煞車 (垂直仕様) With Brake (Vertical Type)	200	220	HG-KR23B	MR-J4-20A
國際 Panasonic	P	無煞車 (水平仕様) No Brake (Horizontal Type)	200	220	MHMD022G1U	MADHT1507
		有煞車 (垂直仕様) With Brake (Vertical Type)	200	220	MHMD022G1V	MADHT1507
台達 Delta	T	無煞車 (水平仕様) No Brake (Horizontal Type)	200	220	ECMA-C20602ES	ASD-B20221-B
		有煞車 (垂直仕様) With Brake (Vertical Type)	200	220	ECMA-C20602FS	ASD-B20221-B

## 馬達直結 / 馬達外露

Motor Hidden In / Motor Exposed

### M 馬達直結 Motor Hidden In



Download CAD data at [www.toyorobot.com](http://www.toyorobot.com)

單位 Unit : mm

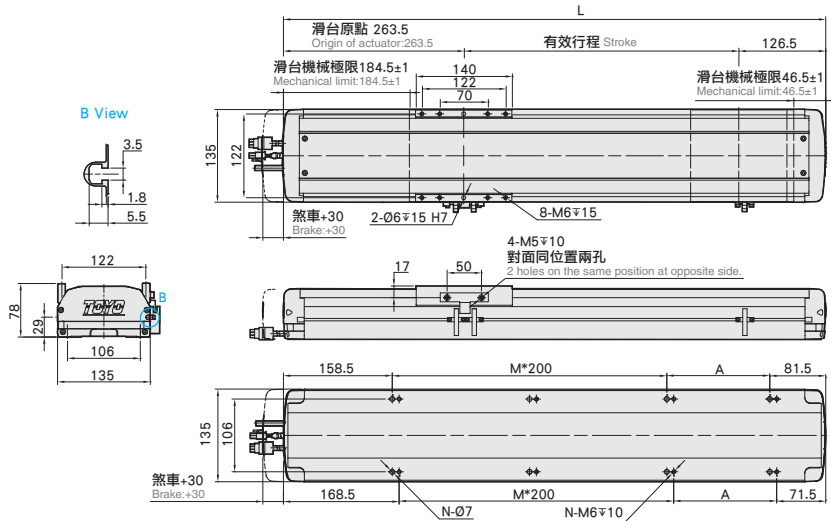

有效行程 Stroke	50	100	150	200	250	300	350	400	450	500	550	600	650	700	750	800	850	900	950	1000	1050	
L	440	490	540	590	640	690	740	790	840	890	940	990	1040	1090	1140	1190	1240	1290	1340	1390	1440	
A	200	50	100	150	200	50	100	150	200	50	100	150	200	50	100	150	200	50	100	150	200	
M	0	1	1	1	1	2	2	2	2	3	3	3	3	4	4	4	4	5	5	5	5	
N	4	6	6	6	6	8	8	8	8	10	10	10	10	10	12	12	12	12	14	14	14	14
KG	9.5	10.06	10.62	11.18	11.74	12.3	12.86	13.42	13.98	14.54	15.1	15.66	16.22	16.78	17.34	17.9	18.46	19.02	19.58	20.14	20.7	

### BC 馬達外露 Motor Exposed



Download CAD data at [www.toyorobot.com](http://www.toyorobot.com)

單位 Unit : mm

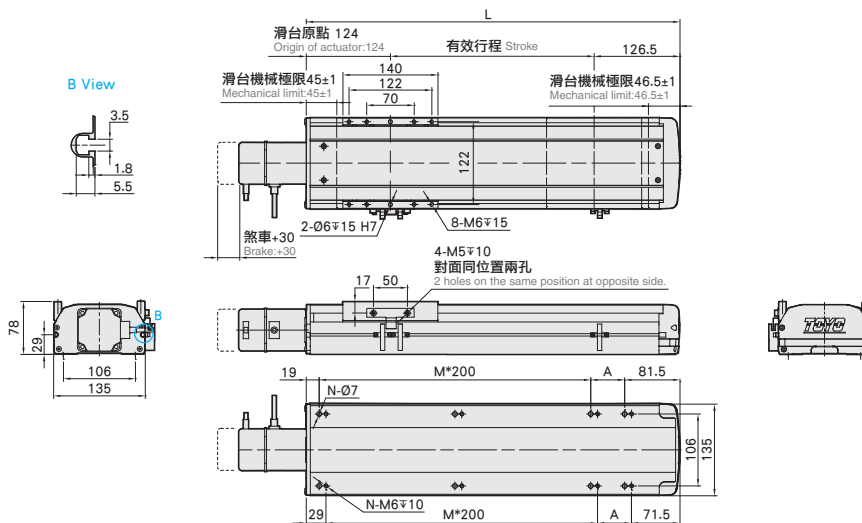

有效行程 Stroke	50	100	150	200	250	300	350	400	450	500	550	600	650	700	750	800	850	900	950	1000	1050	
L	300.5	350.5	400.5	450.5	500.5	550.5	600.5	650.5	700.5	750.5	800.5	850.5	900.5	950.5	1000.5	1050.5	1100.5	1150.5	1200.5	1250.5	1300.5	
A	200	50	100	150	200	50	100	150	200	50	100	150	200	50	100	150	200	50	100	150	200	
M	0	1	1	1	1	2	2	2	2	3	3	3	3	4	4	4	4	5	5	5	5	
N	4	6	6	6	6	8	8	8	8	10	10	10	10	10	12	12	12	12	14	14	14	14
KG	8.75	9.3	9.85	10.4	10.95	11.5	12.05	12.6	13.15	13.7	14.25	14.8	15.35	15.9	16.45	17	17.55	18.1	18.65	19.2	19.75	

# 馬達左折 / 馬達右折

## Motor Left Side / Motor Right Side

**BL 馬達左折 Motor Left Side**   [Download CAD data at www.toyorobot.com](http://www.toyorobot.com)

單位 Unit : mm

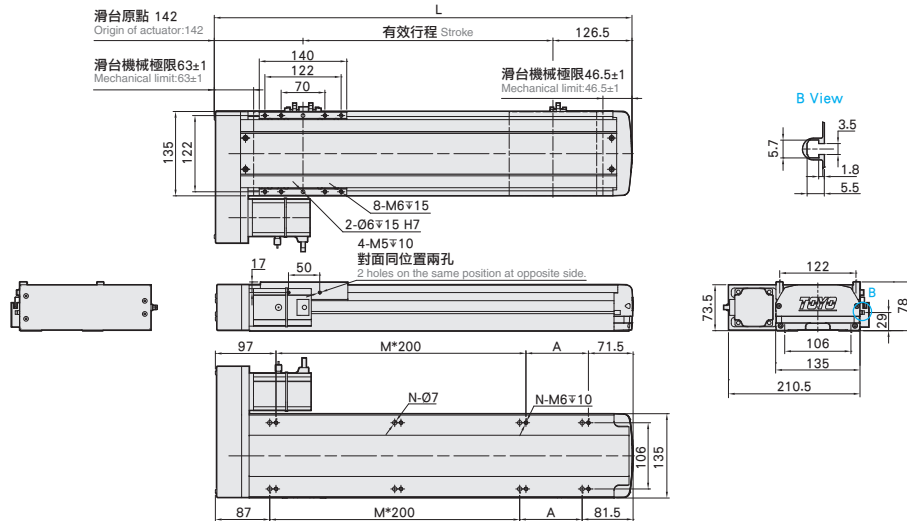

有效行程 Stroke	50	100	150	200	250	300	350	400	450	500	550	600	650	700	750	800	850	900	950	1000	1050
L	318.5	368.5	418.5	468.5	518.5	568.5	618.5	668.5	718.5	768.5	818.5	868.5	918.5	968.5	1018.5	1068.5	1118.5	1168.5	1218.5	1268.5	1318.5
A	150	200	50	100	150	200	50	100	150	200	50	100	150	200	50	100	150	200	50	100	150
M	0	0	1	1	1	1	2	2	2	2	3	3	3	3	4	4	4	4	5	5	5
N	4	4	6	6	6	6	8	8	8	8	10	10	10	10	12	12	12	12	14	14	14
KG	9.4	9.94	10.48	11.02	11.56	12.1	12.64	13.18	13.72	14.26	14.8	15.34	15.88	16.42	16.96	17.5	18.04	18.58	19.12	19.66	20.2

**BR 馬達右折 Motor Right Side**   [Download CAD data at www.toyorobot.com](http://www.toyorobot.com)

單位 Unit : mm

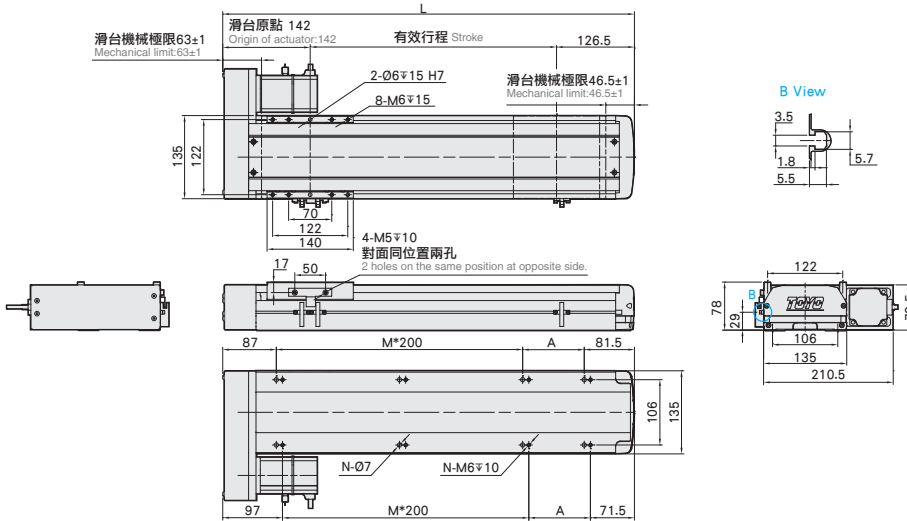

有效行程 Stroke	50	100	150	200	250	300	350	400	450	500	550	600	650	700	750	800	850	900	950	1000	1050
L	318.5	368.5	418.5	468.5	518.5	568.5	618.5	668.5	718.5	768.5	818.5	868.5	918.5	968.5	1018.5	1068.5	1118.5	1168.5	1218.5	1268.5	1318.5
A	150	200	50	100	150	200	50	100	150	200	50	100	150	200	50	100	150	200	50	100	150
M	0	0	1	1	1	1	2	2	2	2	3	3	3	3	4	4	4	4	5	5	5
N	4	4	6	6	6	6	8	8	8	8	10	10	10	10	12	12	12	12	14	14	14
KG	9.4	9.94	10.48	11.02	11.56	12.1	12.64	13.18	13.72	14.26	14.8	15.34	15.88	16.42	16.96	17.5	18.04	18.58	19.12	19.66	20.2

應用例  
Application

一般 / 螺桿仕様  
ETH Series

一般 / 皮帶仕様  
ETB / M

無塵 / 螺桿仕様  
GCH / ECH

無塵 / 皮帶仕様  
ECB

直交連結  
XYGT / XYTH / XYTB

參考資料  
Reference

單軸  
1 axis  
ETH

ETH13

ETH14

ETH17

ETH22

ETH17M

ETH22M

## 馬達下折 Motor Bottom Side

單位 Unit : mm

BM 馬達下折 Motor Bottom Side   [Download CAD data at www.toyorobot.com](http://www.toyorobot.com)

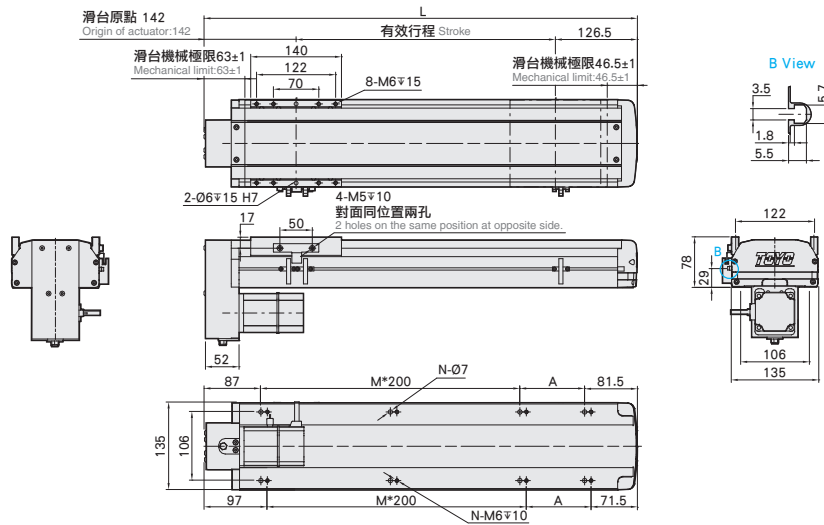

有效行程 Stroke	50	100	150	200	250	300	350	400	450	500	550	600	650	700	750	800	850	900	950	1000	1050
L	318.5	368.5	418.5	468.5	518.5	568.5	618.5	668.5	718.5	768.5	818.5	868.5	918.5	968.5	1018.5	1068.5	1118.5	1168.5	1218.5	1268.5	1318.5
A	150	200	50	100	150	200	50	100	150	200	50	100	150	200	50	100	150	200	50	100	150
M	0	0	1	1	1	1	2	2	2	3	3	3	3	4	4	4	4	4	5	5	5
N	4	4	6	6	6	6	8	8	8	8	10	10	10	10	12	12	12	12	14	14	14
KG	9.4	9.94	10.48	11.02	11.56	12.1	12.64	13.18	13.72	14.26	14.8	15.34	15.88	16.42	16.96	17.5	18.04	18.58	19.12	19.66	20.2

免費服務專線：大陸 400-875-0009 台灣 0800-800-893  
Toll-free Number China Taiwan

應用例  
Application

一般 / 螺桿仕様  
ETH Series

一般 / 皮帶仕様  
ETB / M

無塵 / 螺桿仕様  
GCH / ECH

無塵 / 皮帶仕様  
ECB

直交連結  
XYGT / XYTH / XYTB

參考資料  
Reference

單軸  
1 axis  
**ETH**

ETH13

ETH14

ETH17

ETH22

ETH17M

ETH22M

# MEMO

# ETH14 單軸 / 1-axis

▶ 螺桿驅動  
Ball Screw Drive



精度  
±0.005 mm

此圖僅供參考，出貨規格詳見尺寸圖面  
The picture is just for the reference. Please check the actual dimensions on the drawing.

- 最大行程 Maximum Stroke **1050mm**
- 最高速度 Maximum Speed **1600mm/s**
- 馬達容量 Motor output **400W**
- 滾珠螺桿 Ball Screw **Ø 16mm**
- 直線滑軌 Linear Guide **15X12.5-2 支**

## 型號表示方式 Ordering Method

# ETH14 - L5 - 50 - M - M40B - C4 - 0001

本體型號  
Model

行程  
Stroke  
50-1050mm  
50間隔 50 mm Pitch

特注式樣  
Special Order No.

■ 螺桿導程  
Ball Screw Lead

5	5mm
10	10mm
20	20mm
32	32mm

■ 馬達位置  
Motor Position

M	馬達直結 Motor built-in
BC	馬達外露 Motor Exposed
BL	馬達左折 Motor On Left Side
BR	馬達右折 Motor On Right Side
BM	馬達下折 Motor On Lower Side

■ 馬達廠牌  
Motor Brand

M	三菱 Mitsubishi	10	-	B
P	國際 Panasonic	20	-	
Y	安川 Yaskawa	40	400W	
T	台達 Delta	75	-	

\*若無煞車則不表示。\* If No Brake, No Description.

■ 原點感應器  
Home Sensor

內置型 In Side	
A	馬達側 Motor Side
B	反馬達側 Opposite Motor Side
外掛型 Out Side	
C	馬達側 Motor Side
D	反馬達側 Opposite Motor Side
無 SENSOR	No Sensor
E	無 SENSOR No Sensor

■ 端點極限感應器  
Limit Sensor

內置型 In Side	
1	1只 1 Pc
2	2只 2 Pc
外掛型 Out Side	
3	1只 1 Pc
4	2只 2 Pc
無 SENSOR	No Sensor
5	無 SENSOR No Sensor

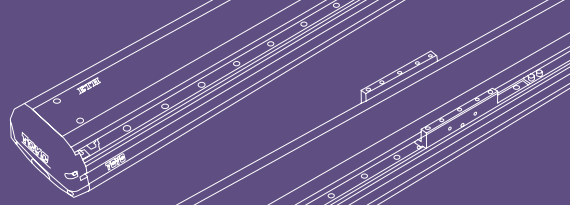

應用例  
Application

一般 / 螺桿仕様  
ETH Series

一般 / 皮帶仕様  
ETB / M

無塵 / 螺桿仕様  
GCH / ECH

無塵 / 皮帶仕様  
ECB

直交連結  
XYGT / XYTH / XYTB

參考資料  
Reference

單軸  
1 axis  
ETH

ETH13

ETH14

ETH17

ETH22

ETH17M

ETH22M

**基本仕様 Specification**

規格 Spec	位置重複精度 Repeatability (mm)	±0.005				
	螺桿導程 Ball Screw Lead (mm)	5	10	20	32	
	最高速度 Maximum Speed (mm/s)*1	250	500	1000	1600	
	最大可搬重量 Maximum Payload	水平使用 Horizontal (kg)	110	88	40	30
		垂直使用 Vertical (kg)	33	22	10	8
定格推力 Rated Thrust (N)	1388 694 347 218					
部品 Parts	標準行程 Stroke Pitch (mm) **2	50-1050mm/50 間隔 50 mm Pitch				
	AC 伺服馬達容量 AC Servo Motor Output (W)	400				
	滾珠螺桿外徑 Ball Screw Ø (mm)	C7Ø16				
	高剛性直線滑軌, High Rigidity Linear Guide (mm)	W15XH12.5				
	連軸器 Coupling (mm)	10X14				
	原點感應器 Home Sensor	外掛 Outside	EE-SX672(NPN)			
		內置 Built-In	EE-SX674(NPN)			

\*1 馬達加減速設定 0.2 秒。  
 Acceleration and deceleration value is set 0.2 second.  
 \*\*2 行程超過 750 時，會產生螺桿偏擺，此時請將速度調降。  
 When the stroke is over 750mm, the run-out of the ballscrew will occur. We recommend to low down the working speed under this circumstances.

**感應器接線圖 < 原點及端點 > Sensor Layout**

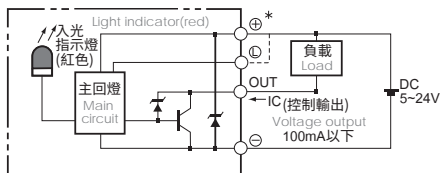

**容許負載力距表 Allowable Overhang**

水平安裝 Horizontal Installation				壁掛安裝 Wall Installation				垂直安裝 Vertical Installation			
導程 Lead	A	B	C	導程 Lead	A	B	C	導程 Lead	A	C	
5	60kg	2512	242	232	55kg	257	269	2883	15kg	1118	1118
	80kg	1811	172	164	75kg	178	186	2000	22kg	770	770
	110kg	1284	114	108	110kg	108	114	1284	33kg	513	513
10	30kg	2727	470	430	35kg	363	395	2368	10kg	1500	1500
	50kg	1577	266	242	55kg	218	238	1445	14kg	1072	1072
	88kg	854	134	122	88kg	123	134	854	22kg	682	682
20	10kg	2304	1222	1028	12kg	854	1019	2552	7kg	1700	1700
	22kg	1443	540	451	20kg	500	596	1588	10kg	1188	1188
	40kg	860	277	233	40kg	233	277	860	-	-	-
32	15kg	1033	545	405	15kg	405	545	1033	5kg	1503	1503
	25kg	604	311	233	30kg	188	251	495	8kg	944	944
	30kg	495	251	188	-	-	-	-	-	-	-

**靜態容許負載慣量 Static Loading Moment**

MY	MP	MR
551	552	455

\* 力距表所表示的數據，代表重心。  
 The torque value in the chart indicate the center of gravity.  
 \* 符合型錄規範的正常使用下，保證壽命為 10000 公里。  
 Operation life is 10,000km when the product is using under the specified conditions.  
 \* 倒吊使用無法套用標準規範，如有需求請洽詢我司業務。  
 Data information is not for ceiling-mount inverse use.  
 Contact us for the details if you want to apply ceiling-mount inverse usage.

**搭配伺服馬達一覽表 Suitable Motor Brand**

廠牌 Brand	馬達記號 Mark	煞車有無 Brake	馬達容量 Watt	電源電壓 AC-Voltage	伺服馬達型號 Motor Model	驅動器型號 Driver Model
三菱 Mitsubishi	M	無煞車 (水平仕様) No Brake (Horizontal Type)	400	220	HG-KR43	MR-J4-40A
		有煞車 (垂直仕様) With Brake (Vertical Type)	400	220	HG-KR43B	MR-J4-40A
國際 Panasonic	P	無煞車 (水平仕様) No Brake (Horizontal Type)	400	220	MHMD042G1U	MBDHT2510
		有煞車 (垂直仕様) With Brake (Vertical Type)	400	220	MHMD042G1V	MBDHT2510
台達 Delta	T	無煞車 (水平仕様) No Brake (Horizontal Type)	400	220	ECMA-C20604ES	ASD-B20421-B
		有煞車 (垂直仕様) With Brake (Vertical Type)	400	220	ECMA-C20604FS	ASD-B20421-B

## 馬達直結 / 馬達外露

Motor Hidden In / Motor Exposed

### M 馬達直結 Motor Hidden In



Download CAD data at [www.toyorobot.com](http://www.toyorobot.com)

單位 Unit : mm

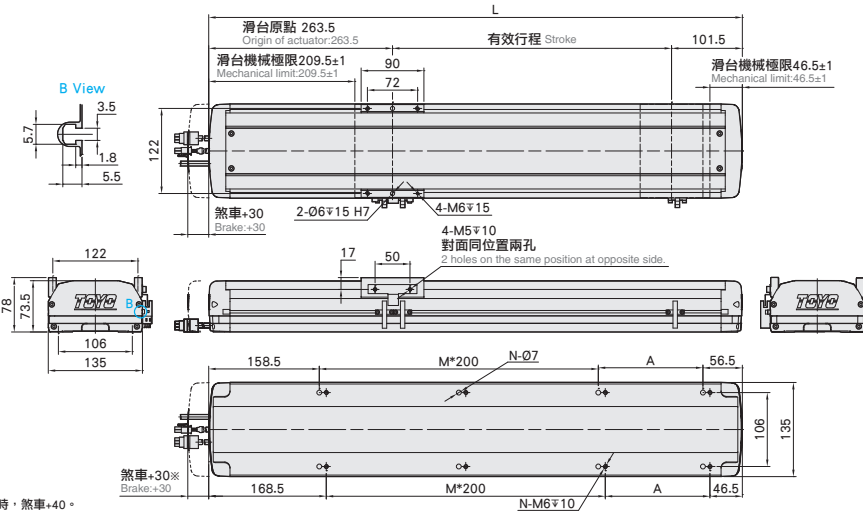

有效行程 Stroke	50	100	150	200	250	300	350	400	450	500	550	600	650	700	750	800	850	900	950	1000	1050
L	440	490	540	590	640	690	740	790	840	890	940	990	1040	1090	1140	1190	1240	1290	1340	1390	1440
A	200	50	100	150	200	50	100	150	200	50	100	150	200	50	100	150	200	50	100	150	200
M	0	1	1	1	1	2	2	2	2	3	3	3	3	4	4	4	4	5	5	5	5
N	4	6	6	6	6	8	8	8	8	10	10	10	10	12	12	12	12	14	14	14	14
KG	9.5	10.06	10.62	11.18	11.74	12.3	12.86	13.42	13.98	14.54	15.1	15.66	16.22	16.78	17.34	17.9	18.46	19.02	19.58	20.14	20.7

### BC 馬達外露 Motor Exposed



Download CAD data at [www.toyorobot.com](http://www.toyorobot.com)

單位 Unit : mm

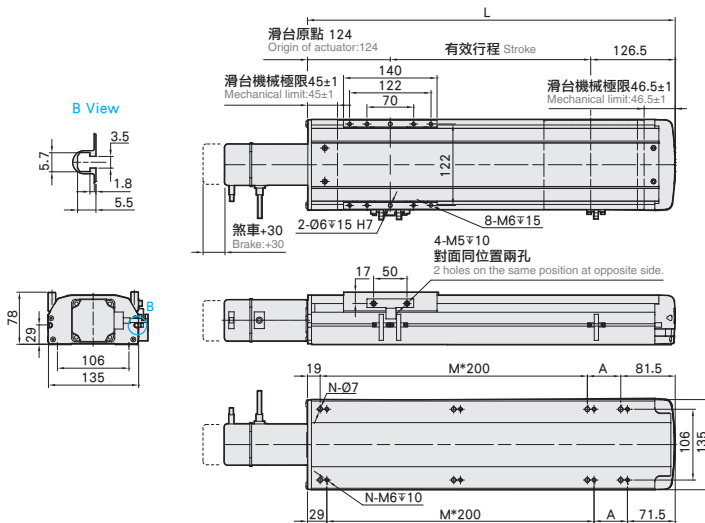

有效行程 Stroke	50	100	150	200	250	300	350	400	450	500	550	600	650	700	750	800	850	900	950	1000	1050
L	300.5	350.5	400.5	450.5	500.5	550.5	600.5	650.5	700.5	750.5	800.5	850.5	900.5	950.5	1000.5	1050.5	1100.5	1150.5	1200.5	1250.5	1300.5
A	200	50	100	150	200	50	100	150	200	50	100	150	200	50	100	150	200	50	100	150	200
M	0	1	1	1	1	2	2	2	2	3	3	3	3	4	4	4	4	5	5	5	5
N	4	6	6	6	6	8	8	8	8	10	10	10	10	12	12	12	12	14	14	14	14
KG	8.75	9.3	9.85	10.4	10.95	11.5	12.05	12.6	13.15	13.7	14.25	14.8	15.35	15.9	16.45	17	17.55	18.1	18.65	19.2	19.75



# 馬達左折 / 馬達右折

## Motor Left Side / Motor Right Side

**BL 馬達左折 Motor Left Side**   [Download CAD data at www.toyorobot.com](http://www.toyorobot.com)

單位 Unit : mm

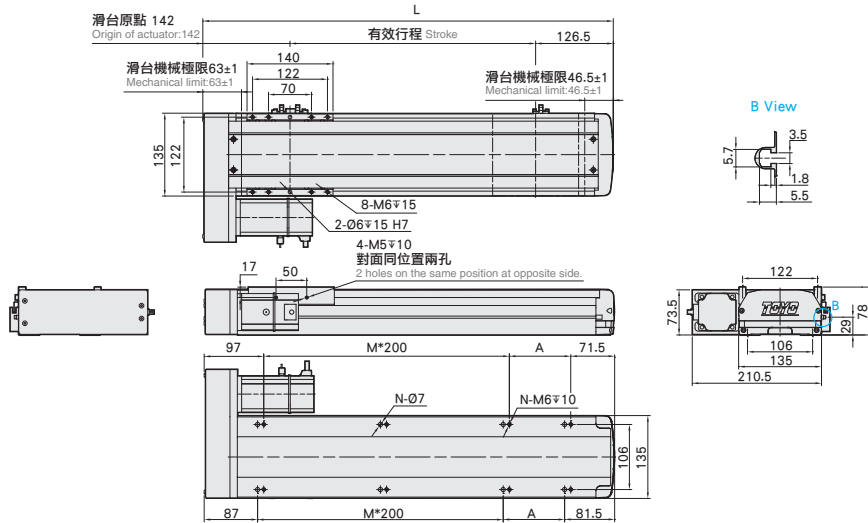

有效行程 Stroke	50	100	150	200	250	300	350	400	450	500	550	600	650	700	750	800	850	900	950	1000	1050
L	318.5	368.5	418.5	468.5	518.5	568.5	618.5	668.5	718.5	768.5	818.5	868.5	918.5	968.5	1018.5	1068.5	1118.5	1168.5	1218.5	1268.5	1318.5
A	150	200	50	100	150	200	50	100	150	200	50	100	150	200	50	100	150	200	50	100	150
M	0	0	1	1	1	1	2	2	2	2	3	3	3	3	4	4	4	4	5	5	5
N	4	4	6	6	6	6	8	8	8	8	10	10	10	10	12	12	12	12	14	14	14
KG	9.4	9.94	10.48	11.02	11.56	12.1	12.64	13.18	13.72	14.26	14.8	15.34	15.88	16.42	16.96	17.5	18.04	18.58	19.12	19.66	20.2

**BR 馬達右折 Motor Right Side**   [Download CAD data at www.toyorobot.com](http://www.toyorobot.com)

單位 Unit : mm

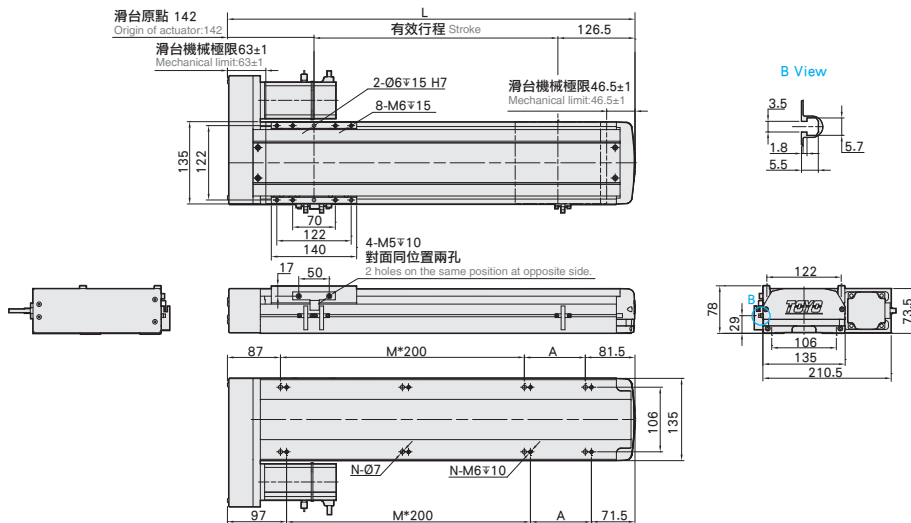

有效行程 Stroke	50	100	150	200	250	300	350	400	450	500	550	600	650	700	750	800	850	900	950	1000	1050
L	318.5	368.5	418.5	468.5	518.5	568.5	618.5	668.5	718.5	768.5	818.5	868.5	918.5	968.5	1018.5	1068.5	1118.5	1168.5	1218.5	1268.5	1318.5
A	150	200	50	100	150	200	50	100	150	200	50	100	150	200	50	100	150	200	50	100	150
M	0	0	1	1	1	1	2	2	2	2	3	3	3	3	4	4	4	4	5	5	5
N	4	4	6	6	6	6	8	8	8	8	10	10	10	10	12	12	12	12	14	14	14
KG	9.4	9.94	10.48	11.02	11.56	12.1	12.64	13.18	13.72	14.26	14.8	15.34	15.88	16.42	16.96	17.5	18.04	18.58	19.12	19.66	20.2

應用例  
Application

一般 / 螺桿仕様  
ETH Series

一般 / 皮帶仕様  
ETB / M

無塵 / 螺桿仕様  
GCH / ECH

無塵 / 皮帶仕様  
ECB

直交連結  
XYGT / XYTH / XYTB

參考資料  
Reference

單軌  
1 axis  
ETH

ETH13

ETH14

ETH17

ETH22

ETH17M

ETH22M

## 馬達下折 Motor Bottom Side

單位 Unit : mm

BM 馬達下折 Motor Bottom Side   [Download CAD data at www.toyorobot.com](http://www.toyorobot.com)

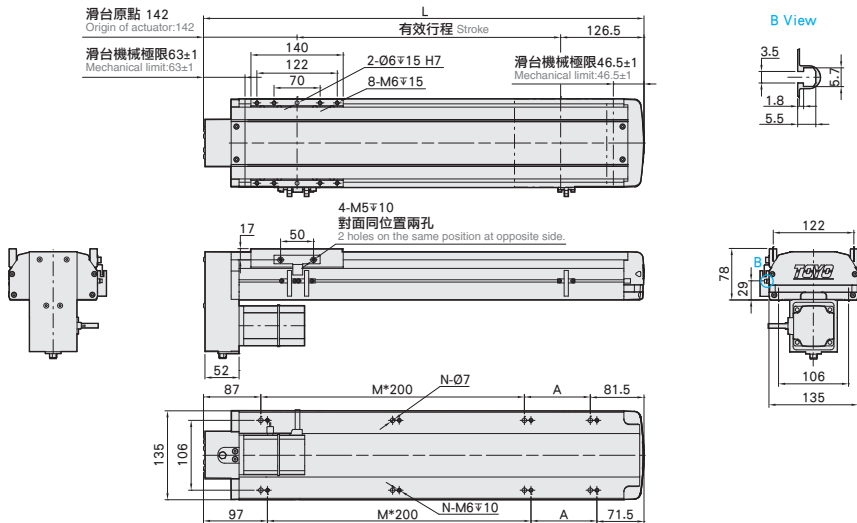

有效行程 Stroke	50	100	150	200	250	300	350	400	450	500	550	600	650	700	750	800	850	900	950	1000	1050
L	318.5	368.5	418.5	468.5	518.5	568.5	618.5	668.5	718.5	768.5	818.5	868.5	918.5	968.5	1018.5	1068.5	1118.5	1168.5	1218.5	1268.5	1318.5
A	150	200	50	100	150	200	50	100	150	200	50	100	150	200	50	100	150	200	50	100	150
M	0	0	1	1	1	1	2	2	2	3	3	3	3	4	4	4	4	4	5	5	5
N	4	4	6	6	6	6	8	8	8	8	10	10	10	10	12	12	12	12	14	14	14
KG	9.4	9.94	10.48	11.02	11.56	12.1	12.64	13.18	13.72	14.26	14.8	15.34	15.88	16.42	16.96	17.5	18.04	18.58	19.12	19.66	20.2

免費服務專線：大陸 400-875-0009 台灣 0800-800-893  
Toll-free Number China Taiwan

# MEMO

應用例  
Application

一般 / 螺桿仕様  
ETH Series

一般 / 皮帶仕様  
ETB / M

無塵 / 螺桿仕様  
GCH / ECH

無塵 / 皮帶仕様  
ECB

直交連結  
XYGT / XYTH / XYTB

參考資料  
Reference

單軸  
1 axis  
**ETH**

ETH13

ETH14

ETH17

ETH22

ETH17M

ETH22M

# ETH17 單軸 / 1-axis

▶ 螺桿驅動  
Ball Screw Drive



精度 ↑  
±0.005 mm

此圖僅供參考，出貨規格詳見尺寸圖面  
The picture is just for the reference. Please check the actual dimensions on the drawing.

- 最大行程 Maximum Stroke **1250mm**
- 最高速度 Maximum Speed **2000mm/s**
- 馬達容量 Motor output **400W**
- 滾珠螺桿 Ball Screw **Ø20mm**
- 直線滑軌 Linear Guide **20X15-2 支**

## 型號表示方式 Ordering Method

# ETH17 - L5 - 100 - M - M40B - C4 - 0001

本體型號  
Model

特注式樣  
Special Order No.

行程  
Stroke  
50-1250mm  
50間隔 50 mm Pitch

馬達位置  
Motor Position

M	馬達直結 Motor Hidden In
BC	馬達外露 Motor Exposed
BL	馬達左折 Motor Left Side
BR	馬達右折 Motor Right Side
BM	馬達下折 Motor Bottom Side

馬達廠牌  
Motor Brand

M	三菱 Mitsubishi	10	-	B
P	國際 Panasonic	20	-	
Y	安川 Yaskawa	40	400W	
T	台達 Delta	75	-	

\*若無煞車則不表示。\* If No Brake, No Description.

原點感應器  
Home Sensor

內置型 In Side	
A	馬達側 Motor Side
B	反馬達側 Opposite Motor Side
外掛型 Out Side	
C	馬達側 Motor Side
D	反馬達側 Opposite Motor Side
	無 SENSOR No Sensor
E	無 SENSOR No Sensor

端點極限感應器  
Limit Sensor

內置型 In Side	
1	1只 1 Pc
2	2只 2 Pc
外掛型 Out Side	
3	1只 1 Pc
4	2只 2 Pc
	無 SENSOR No Sensor
5	無 SENSOR No Sensor

螺桿導程  
Ball Screw Lead

5	5mm
10	10mm
20	20mm
40	40mm

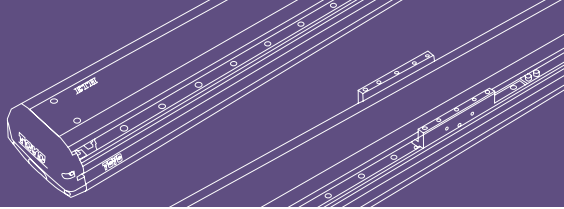

應用例  
Application

一般 / 螺桿仕様  
ETH Series

一般 / 皮帶仕様  
ETB / M

無塵 / 螺桿仕様  
GCH / ECH

無塵 / 皮帶仕様  
ECB

直交連結  
XYGT / XYTH / XYTB

參考資料  
Reference

基本仕様 Specification

規格 Spec	位置重複精度 Repeatability (mm)	±0.005				
	螺桿導程 Ball Screw Lead (mm)	5	10	20	40	
	最高速度 Maximum Speed (mm/s) ※1	250	500	1000	2000	
	最大可搬重量 Maximum Payload	水平使用 Horizontal (kg)	120	110	75	22
		垂直使用 Vertical (kg)	40	30	14	7
	定格推力 Rated Thrust (N)	1388 694 347 147				
部品 Parts	標準行程 Stroke Pitch (mm) ※2	50-1250mm/50 間隔 50 mm Pitch				
	AC 伺服馬達容量 AC Servo Motor Output (W)	400				
	滾珠螺桿外徑 Ball Screw Ø (mm)	C7Ø20				
	高剛性直線滑軌, High Rigidity Linear Guide (mm)	W20XH15				
	連軸器 Coupling (mm)	12X14				
	原點感應器 Home Sensor	外掛 Outside	EE-SX672(NPN)			
內置 Built-In		EE-SX674(NPN)				

※1 馬達加速減速設定 0.2 秒。  
Acceleration and deceleration value is set 0.2 second.  
※2 行程超過 850 時，會產生螺桿偏擺，此時請將速度調降。  
When the stroke is over 850mm, the run-out of the ballscrew will occur. We recommend to low down the working speed under this circumstances.

感應器接線圖 < 原點及端點 > Sensor Layout

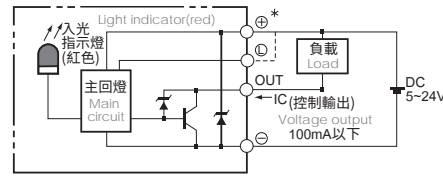

容許負載力距表 Allowable Overhang

水平安裝 Horizontal Installation				壁掛安裝 Wall Installation				垂直安裝 Vertical Installation			
導程 Lead	A	B	C	導程 Lead	A	B	C	導程 Lead	A	C	
5	70kg	3235	349	408	75kg	377	322	2988	20kg	1368	1368
	90kg	2482	263	306	95kg	288	246	2333	30kg	911	911
	120kg	1850	187	217	120kg	218	187	1850	40kg	683	683
10	65kg	1911	338	373	60kg	408	368	2092	15kg	1618	1618
	85kg	1445	248	276	80kg	296	266	1554	25kg	970	970
	110kg	1102	182	202	110kg	202	182	1102	30kg	808	808
20	35kg	1666	547	538	30kg	633	644	1961	10kg	1922	1922
	55kg	1030	331	328	50kg	365	369	1143	14kg	1377	1377
	75kg	733	231	230	75kg	230	231	733	-	-	-
40	15kg	1126	740	577	12kg	729	936	1417	4kg	2377	2377
	22kg	755	491	384	22kg	384	491	755	7kg	1356	1356
	-	-	-	-	-	-	-	-	-	-	-

靜態容許負載慣量 Static Loading Moment

MY	MP	MR
1032	1034	908

\* 力距表所表示的數據，代表重心。  
The torque value in the chart indicate the center of gravity.  
\* 符合型錄規範的正常使用下，保證壽命為 10000 公里。  
Operation life is 10,000km when the product is using under the specified conditions.  
\* 倒吊使用無法套用標準規範，如有需求請洽詢我司業務。  
Data information is not for ceiling-mount inverse use.  
Contact us for the details if you want to apply ceiling-mount inverse usage.

搭配伺服馬達一覽表 Suitable Motor Brand

廠牌 Brand	馬達記號 Mark	煞車有無 Brake	馬達容量 Watt	電源電壓 AC-Voltage	伺服馬達型號 Motor Model	驅動器型號 Driver Model
三菱 Mitsubishi	M	無煞車 (水平仕様) No Brake (Horizontal Type)	400	220	HG-KR43	MR-J4-40A
		有煞車 (垂直仕様) With Brake (Vertical Type)	400	220	HG-KR43B	MR-J4-40A
國際 Panasonic	P	無煞車 (水平仕様) No Brake (Horizontal Type)	400	220	MHMD042G1U	MBDHT2510
		有煞車 (垂直仕様) With Brake (Vertical Type)	400	220	MHMD042G1V	MBDHT2510
台達 Delta	T	無煞車 (水平仕様) No Brake (Horizontal Type)	400	220	ECMA-C20604ES	ASD-B20421-B
		有煞車 (垂直仕様) With Brake (Vertical Type)	400	220	ECMA-C20604FS	ASD-B20421-B

單軸  
1 axis  
ETH

ETH13

ETH14

ETH17

ETH22

ETH17M

ETH22M

## 馬達直結 / 馬達外露

Motor Hidden In / Motor Exposed

### M 馬達直結 Motor Hidden In



Download CAD data at [www.toyorobot.com](http://www.toyorobot.com)

單位 Unit : mm

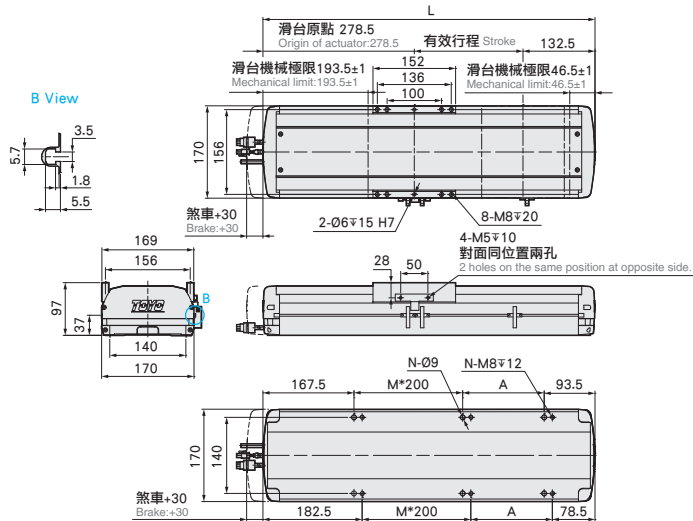

有效行程 Stroke	50	100	150	200	250	300	350	400	450	500	550	600	650	700	750	800	850	900	950	1000	1050	1100	1150	1200	1250
L	461	511	561	611	661	711	761	811	861	911	961	1011	1061	1111	1161	1211	1261	1311	1361	1411	1461	1511	1561	1611	1661
A	200	50	100	150	200	50	100	150	200	50	100	150	200	50	100	150	200	50	100	150	200	50	100	150	200
M	0	1	1	1	1	2	2	2	2	3	3	3	3	4	4	4	4	5	5	5	5	6	6	6	6
N	4	6	6	6	6	8	8	8	8	10	10	10	10	12	12	12	12	14	14	14	14	16	16	16	16
KG	10.11	10.89	11.67	12.45	13.22	14	14.78	15.55	16.33	17.11	17.88	18.66	19.44	20.22	20.99	21.77	22.55	23.33	24.1	24.88	25.66	26.44	27.21	27.99	28.77

### BC 馬達外露 Motor Exposed



Download CAD data at [www.toyorobot.com](http://www.toyorobot.com)

單位 Unit : mm

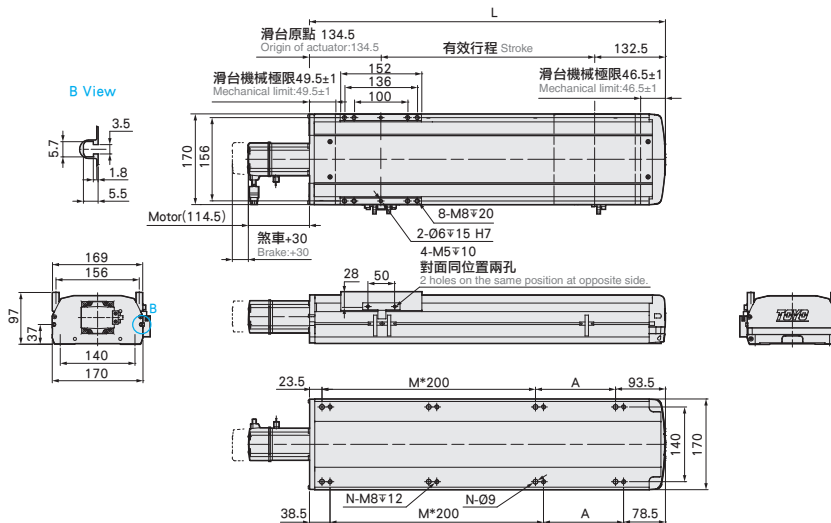

有效行程 Stroke	50	100	150	200	250	300	350	400	450	500	550	600	650	700	750	800	850	900	950	1000	1050	1100	1150	1200	1250
L	317	367	417	467	517	567	617	667	717	767	817	867	917	967	1017	1067	1117	1167	1217	1267	1317	1367	1417	1467	1517
A	200	50	100	150	200	50	100	150	200	50	100	150	200	50	100	150	200	50	100	150	200	50	100	150	200
M	0	1	1	1	1	2	2	2	2	3	3	3	3	4	4	4	4	5	5	5	5	6	6	6	6
N	4	6	6	6	6	8	8	8	8	10	10	10	10	12	12	12	12	14	14	14	14	16	16	16	16
KG	9.61	10.2	10.79	11.57	12.34	13.11	13.88	14.65	15.42	16.19	16.96	17.73	18.5	19.28	20.05	20.82	21.59	22.36	23.13	23.9	24.67	25.44	26.21	26.98	27.75

# 馬達左折 / 馬達右折

## Motor Left Side / Motor Right Side

**BL 馬達左折 Motor Left Side**   [Download CAD data at www.toyorobot.com](http://www.toyorobot.com)

單位 Unit : mm

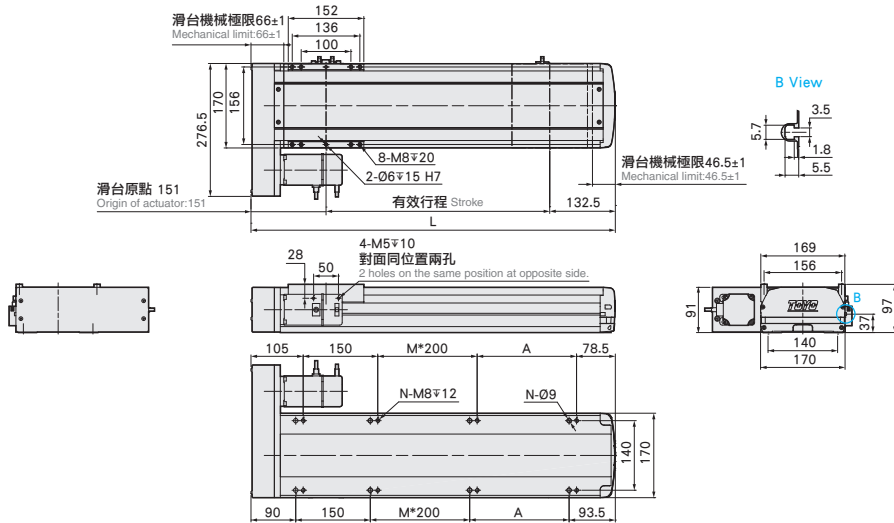

有效行程 Stroke	50	100	150	200	250	300	350	400	450	500	550	600	650	700	750	800	850	900	950	1000	1050	1100	1150	1200	1250
L	333.5	383.5	433.5	483.5	533.5	583.5	633.5	683.5	733.5	783.5	833.5	883.5	933.5	983.5	1033.5	1083.5	1133.5	1183.5	1233.5	1283.5	1333.5	1383.5	1433.5	1483.5	1533.5
A	0	50	100	150	200	50	100	150	200	50	100	150	200	50	100	150	200	50	100	150	200	50	100	150	200
M	0	0	0	0	0	1	1	1	1	2	2	2	2	3	3	3	3	4	4	4	4	5	5	5	5
N	4	6	6	6	6	8	8	8	8	10	10	10	10	12	12	12	12	14	14	14	14	16	16	16	16
KG	9.53	10.3	11.07	11.84	12.61	13.38	14.15	14.92	15.69	16.47	17.24	18.01	18.78	19.55	20.32	21.09	21.86	22.63	23.4	24.18	24.95	25.72	26.49	27.26	28.03

**BR 馬達右折 Motor Right Side**   [Download CAD data at www.toyorobot.com](http://www.toyorobot.com)

單位 Unit : mm

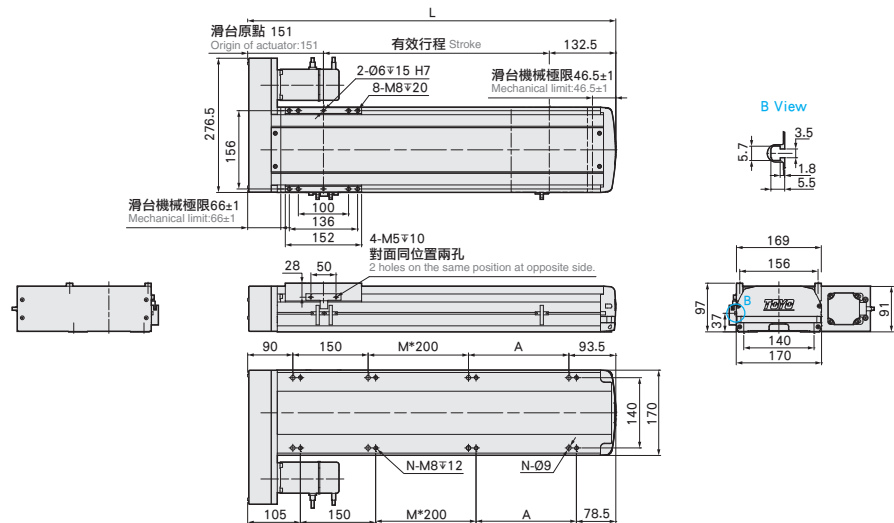

有效行程 Stroke	50	100	150	200	250	300	350	400	450	500	550	600	650	700	750	800	850	900	950	1000	1050	1100	1150	1200	1250
L	333.5	383.5	433.5	483.5	533.5	583.5	633.5	683.5	733.5	783.5	833.5	883.5	933.5	983.5	1033.5	1083.5	1133.5	1183.5	1233.5	1283.5	1333.5	1383.5	1433.5	1483.5	1533.5
A	0	50	100	150	200	50	100	150	200	50	100	150	200	50	100	150	200	50	100	150	200	50	100	150	200
M	0	0	0	0	0	1	1	1	1	2	2	2	2	3	3	3	3	4	4	4	4	5	5	5	5
N	4	6	6	6	6	8	8	8	8	10	10	10	10	12	12	12	12	14	14	14	14	16	16	16	16
KG	9.53	10.3	11.07	11.84	12.61	13.38	14.15	14.92	15.69	16.47	17.24	18.01	18.78	19.55	20.32	21.09	21.86	22.63	23.4	24.18	24.95	25.72	26.49	27.26	28.03

應用例  
 應用例  
 一般 / 螺桿仕様  
 ETH Series  
 一般 / 皮帶仕様  
 ETB / M  
 無塵 / 螺桿仕様  
 GCH / ECH  
 無塵 / 皮帶仕様  
 ECB  
 直交連結  
 XYGT / XYTH / XYTB  
 參考資料  
 Reference

單軸  
 1 axis  
 ETH  
 ETH13  
 ETH14  
 ETH17  
 ETH22  
 ETH17M  
 ETH22M

## 馬達下折

Motor Bottom Side

單位 Unit : mm

BM 馬達下折 Motor Bottom Side   [Download CAD data at www.toyorobot.com](http://www.toyorobot.com)

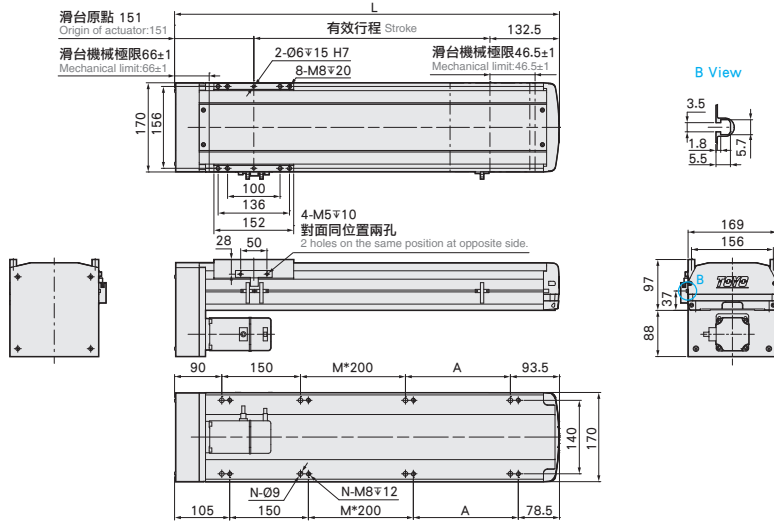

有效行程 Stroke	50	100	150	200	250	300	350	400	450	500	550	600	650	700	750	800	850	900	950	1000	1050	1100	1150	1200	1250
L	333.5	383.5	433.5	483.5	533.5	583.5	633.5	683.5	733.5	783.5	833.5	883.5	933.5	983.5	1033.5	1083.5	1133.5	1183.5	1233.5	1283.5	1333.5	1383.5	1433.5	1483.5	1533.5
A	0	50	100	150	200	50	100	150	200	50	100	150	200	50	100	150	200	50	100	150	200	50	100	150	200
M	0	0	0	0	0	1	1	1	1	2	2	2	2	3	3	3	3	4	4	4	4	5	5	5	5
N	4	6	6	6	6	8	8	8	8	10	10	10	10	12	12	12	12	14	14	14	14	16	16	16	16
KG	9.53	10.3	11.07	11.84	12.61	13.38	14.15	14.92	15.69	16.47	17.24	18.01	18.78	19.55	20.32	21.09	21.86	22.63	23.4	24.18	24.95	25.72	26.49	27.26	28.03



免費服務專線：大陸 400-875-0009 台灣 0800-800-893  
Toll-free Number China Taiwan

應用例  
Application

一般 / 標準仕様  
ETH Series

一般 / 皮帶仕様  
ETB / M

無塵 / 標準仕様  
GCH / ECH

無塵 / 皮帶仕様  
ECB

直交連結  
XYGT / XYTH / XYTB

參考資料  
Reference

# MEMO

單軸  
1 axis  
**ETH**

ETH13

ETH14

**ETH17**

ETH22

ETH17M

ETH22M

# ETH17 單軸 / 1-axis

▶ 螺桿驅動  
Ball Screw Drive



精度 ↑  
±0.005 mm

此圖僅供參考，出貨規格詳見尺寸圖面  
The picture is just for the reference. Please check the actual dimensions on the drawing.

- 最大行程 Maximum Stroke **1250mm**
- 最高速度 Maximum Speed **2000mm/s**
- 馬達容量 Motor output **750W**
- 滾珠螺桿 Ball Screw **Ø20mm**
- 直線滑軌 Linear Guide **20X15-2 支**

## 型號表示方式 Ordering Method

# ETH17 - L5 - 50 - M - M75B - C 4 - 0001

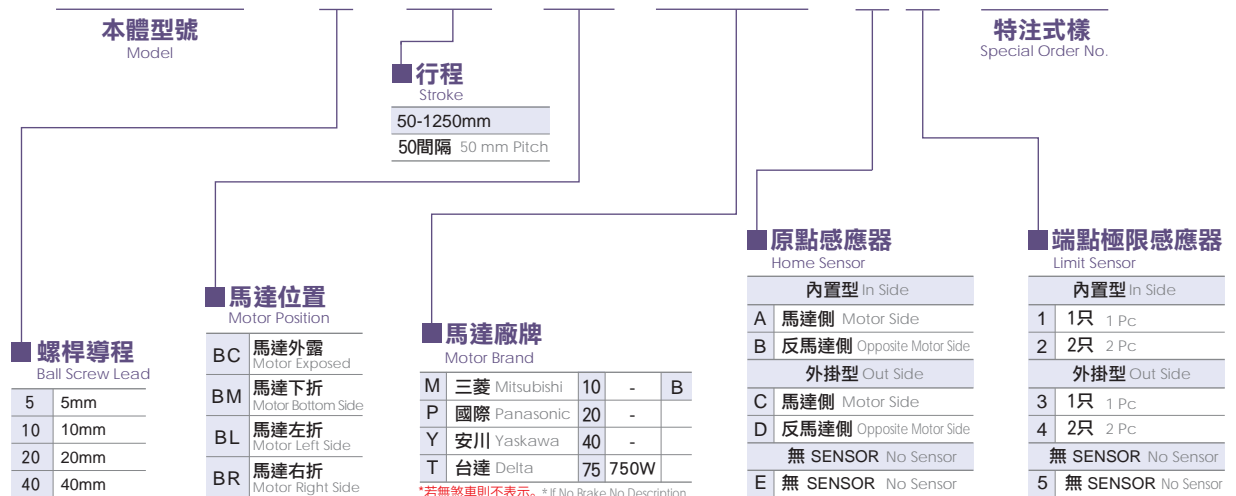

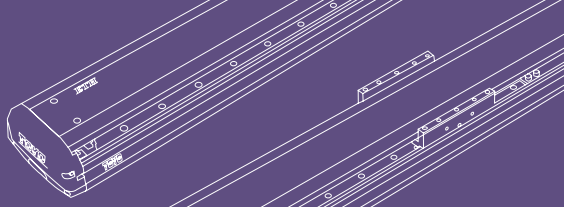

應用例  
Application

一般 / 螺桿仕様  
ETH Series

一般 / 皮帶仕様  
ETB / M

無塵 / 螺桿仕様  
GCH / ECH

無塵 / 皮帶仕様  
ECB

直交連結  
XYGT / XYTH / XYTB

參考資料  
Reference

基本仕様 Specification

規格 Spec	位置重複精度 Repeatability (mm)	±0.005				
	螺桿導程 Ball Screw Lead (mm)	5	10	20	40	
	最高速度 Maximum Speed (mm/s) ※1	250	500	1000	2000	
	最大可搬重量 Maximum Payload	水平使用 Horizontal (kg)	120	120	83	43
		垂直使用 Vertical (kg)	50	40	25	12
	定格推力 Rated Thrust (N)	2563	1281	640	320	
標準行程 Stroke Pitch (mm) ※2	50-1250mm/50 間隔 50 mm Pitch					
部品 Parts	AC 伺服馬達容量 AC Servo Motor Output (W)	750				
	滾珠螺桿外徑 Ball Screw Ø (mm)	C7Ø20				
	高剛性直線滑軌, High Rigidity Linear Guide (mm)	W20XH15				
	連軸器 Coupling (mm)	12X19				
	原點感應器 Home Sensor	外掛 Outside	EE-SX672(NPN)			
	內置 Built-In	EE-SX674(NPN)				

感應器接線圖 < 原點及端點 > Sensor Layout

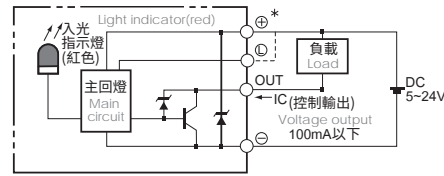

※1 馬達加減速設定 0.2 秒。  
Acceleration and deceleration value is set 0.2 second.  
※2 行程超過 850 時，會產生螺桿偏擺，此時請將速度調降。  
When the stroke is over 850mm, the run-out of the ballscrew will occur. We recommend to low down the working speed under this circumstances.

容許負載力距表 Allowable Overhang

水平安裝 Horizontal Installation				壁掛安裝 Wall Installation				垂直安裝 Vertical Installation			
導程 Lead	A	B	C	導程 Lead	A	B	C	導程 Lead	A	C	
5	70kg	3235	349	408	75kg	377	322	2988	20kg	1368	1368
	90kg	2482	263	306	95kg	288	246	2333	30kg	911	911
	120kg	1861	187	218	120kg	218	187	1850	50kg	546	546
10	65kg	1911	338	373	60kg	408	368	2092	15kg	1618	1618
	85kg	1445	248	276	80kg	296	266	1554	25kg	970	970
	120kg	1000	164	182	120kg	182	164	1002	40kg	607	607
20	35kg	1666	547	538	30kg	633	644	1961	10kg	1922	1922
	55kg	1030	331	328	50kg	365	369	1143	14kg	1377	1377
	83kg	654	206	204	83kg	204	206	656	25kg	769	769
40	15kg	1126	740	577	12kg	729	936	1417	7kg	1356	1356
	22kg	755	491	384	22kg	384	491	755	12kg	790	790
	43kg	366	231	183	43kg	183	231	366	-	-	-

靜態容許負載慣量 Static Loading Moment

MY	MP	MR
1032	1034	908

\* 力距表所表示的數據，代表重心。  
The torque value in the chart indicate the center of gravity.  
\* 符合型錄規範的正常使用下，保證壽命為 10000 公里。  
Operation life is 10,000km when the product is using under the specified conditions.  
\* 倒吊使用無法套用標準規範，如有需求請洽詢我司業務。  
Data information is not for ceiling-mount inverse use.  
Contact us for the details if you want to apply ceiling-mount inverse usage.

搭配伺服馬達一覽表 Suitable Motor Brand

廠牌 Brand	馬達記號 Mark	煞車有無 Brake	馬達容量 Watt	電源電壓 AC-Voltage	伺服馬達型號 Motor Model	驅動器型號 Driver Model
三菱 Mitsubishi	M	無煞車 (水平仕様) No Brake (Horizontal Type)	750	220	HG-KR73	MR-J4-70A
		有煞車 (垂直仕様) With Brake (Vertical Type)	750	220	HG-KR73B	MR-J4-70A
國際 Panasonic	P	無煞車 (水平仕様) No Brake (Horizontal Type)	750	220	MHMD082G1U	MCDHT3520
		有煞車 (垂直仕様) With Brake (Vertical Type)	750	220	MHMD082G1V	MCDHT3520
台達 Delta	T	無煞車 (水平仕様) No Brake (Horizontal Type)	750	220	ECMA-C20807ES	ASD-B20721-B
		有煞車 (垂直仕様) With Brake (Vertical Type)	750	220	ECMA-C20807FS	ASD-B20721-B

單軸  
1 axis  
ETH

ETH13

ETH14

ETH17

ETH22

ETH17M

ETH22M

## 馬達直結 / 馬達外露

Motor Hidden In / Motor Exposed

單位 Unit : mm

BC 馬達直結 Motor Hidden In



Download CAD data at [www.toyorobot.com](http://www.toyorobot.com)

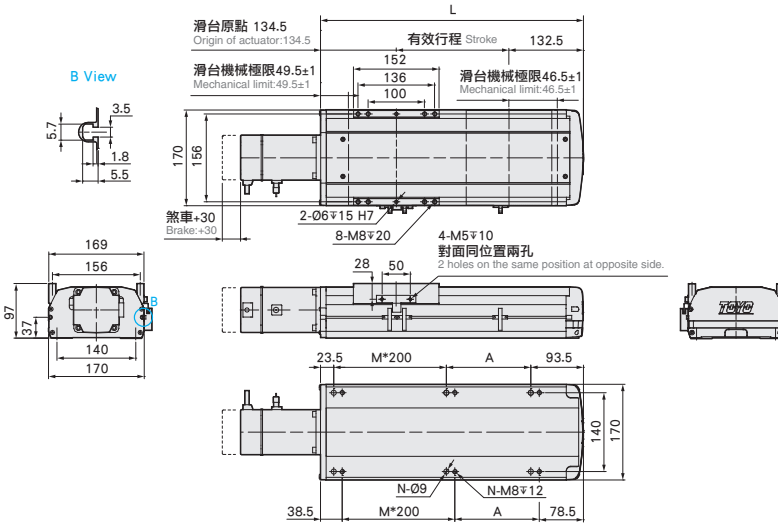

有效行程 Stroke	50	100	150	200	250	300	350	400	450	500	550	600	650	700	750	800	850	900	950	1000	1050	1100	1150	1200	1250
L	317	367	417	467	517	567	617	667	717	767	817	867	917	967	1017	1067	1117	1167	1217	1267	1317	1367	1417	1467	1517
A	200	50	100	150	200	50	100	150	200	50	100	150	200	50	100	150	200	50	100	150	200	50	100	150	200
M	0	1	1	1	1	2	2	2	2	3	3	3	3	4	4	4	4	5	5	5	5	6	6	6	6
N	4	6	6	6	6	8	8	8	8	10	10	10	10	12	12	12	12	14	14	14	14	16	16	16	16
KG	9.61	10.02	10.79	11.57	12.34	13.11	13.88	14.65	15.42	16.19	16.96	17.73	18.5	19.28	20.05	20.82	21.59	22.36	23.13	23.9	24.67	25.44	26.21	26.98	27.75

BM 馬達下折 Motor Bottom Side



Download CAD data at [www.toyorobot.com](http://www.toyorobot.com)

單位 Unit : mm

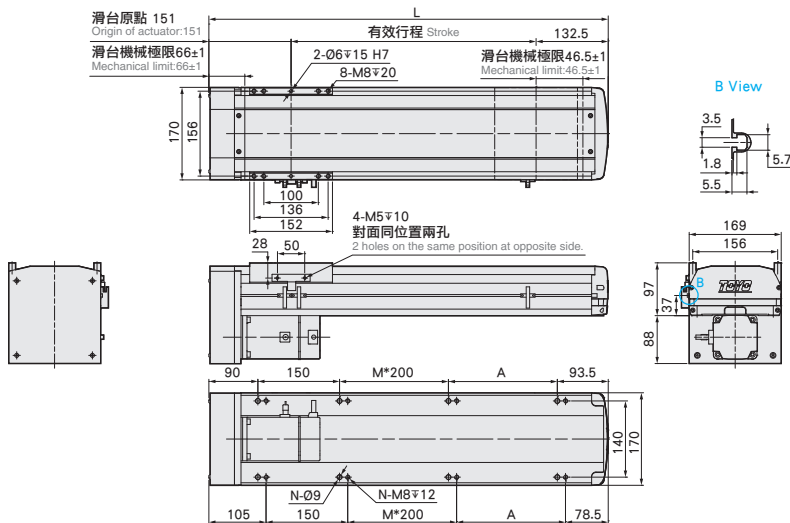

有效行程 Stroke	50	100	150	200	250	300	350	400	450	500	550	600	650	700	750	800	850	900	950	1000	1050	1100	1150	1200	1250
L	333.5	383.5	433.5	483.5	533.5	583.5	633.5	683.5	733.5	783.5	833.5	883.5	933.5	983.5	1033.5	1083.5	1133.5	1183.5	1233.5	1283.5	1333.5	1383.5	1433.5	1483.5	1533.5
A	0	50	100	150	200	50	100	150	200	50	100	150	200	50	100	150	200	50	100	150	200	50	100	150	200
M	0	0	0	0	0	1	1	1	1	2	2	2	2	3	3	3	3	4	4	4	4	5	5	5	5
N	4	6	6	6	6	8	8	8	8	10	10	10	10	12	12	12	12	14	14	14	14	16	16	16	16
KG	9.53	10.3	11.07	11.84	12.61	13.38	14.15	14.92	15.69	16.47	17.24	18.01	18.78	19.55	20.32	21.09	21.86	22.63	23.4	24.18	24.95	25.72	26.49	27.26	28.03

# 馬達左折 / 馬達右折

## Motor Left Side / Motor Right Side

**BL 馬達左折 Motor Left Side**   [Download CAD data at www.toyorobot.com](http://www.toyorobot.com)

單位 Unit : mm

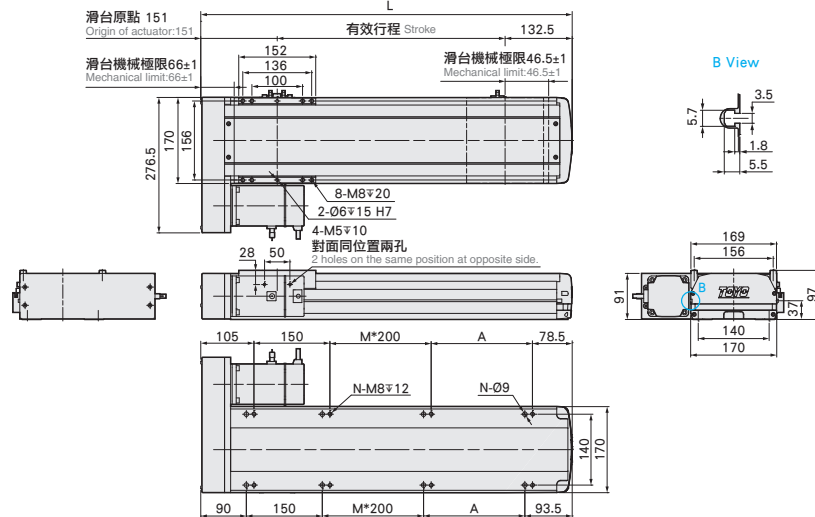

有效行程 Stroke	50	100	150	200	250	300	350	400	450	500	550	600	650	700	750	800	850	900	950	1000	1050	1100	1150	1200	1250
L	333.5	383.5	433.5	483.5	533.5	583.5	633.5	683.5	733.5	783.5	833.5	883.5	933.5	983.5	1033.5	1083.5	1133.5	1183.5	1233.5	1283.5	1333.5	1383.5	1433.5	1483.5	1533.5
A	0	50	100	150	200	50	100	150	200	50	100	150	200	50	100	150	200	50	100	150	200	50	100	150	200
M	0	0	0	0	0	1	1	1	1	2	2	2	2	3	3	3	3	4	4	4	4	5	5	5	5
N	4	6	6	6	6	8	8	8	8	10	10	10	10	12	12	12	12	14	14	14	14	16	16	16	16
KG	9.53	10.3	11.07	11.84	12.61	13.38	14.15	14.92	15.69	16.47	17.24	18.01	18.78	19.55	20.32	21.09	21.86	22.63	23.4	24.18	24.95	25.72	26.49	27.26	28.03

**BR 馬達右折 Motor Right Side**   [Download CAD data at www.toyorobot.com](http://www.toyorobot.com)

單位 Unit : mm

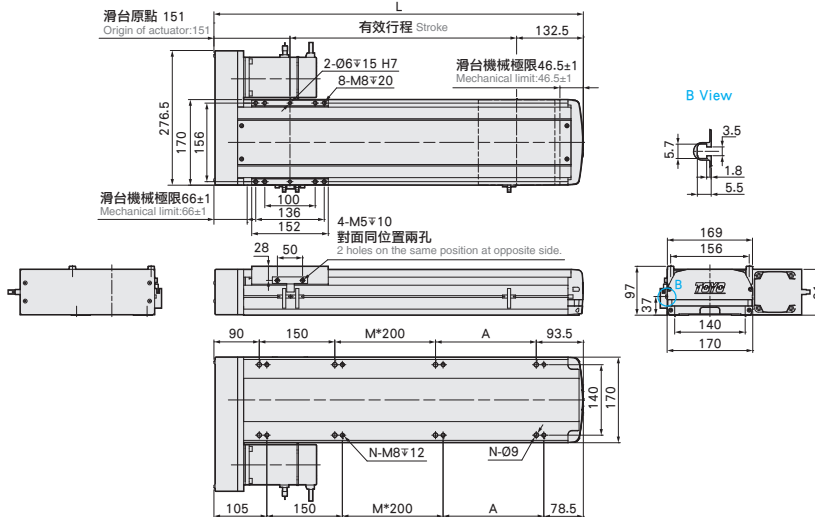

有效行程 Stroke	50	100	150	200	250	300	350	400	450	500	550	600	650	700	750	800	850	900	950	1000	1050	1100	1150	1200	1250
L	333.5	383.5	433.5	483.5	533.5	583.5	633.5	683.5	733.5	783.5	833.5	883.5	933.5	983.5	1033.5	1083.5	1133.5	1183.5	1233.5	1283.5	1333.5	1383.5	1433.5	1483.5	1533.5
A	0	50	100	150	200	50	100	150	200	50	100	150	200	50	100	150	200	50	100	150	200	50	100	150	200
M	0	0	0	0	0	1	1	1	1	2	2	2	2	3	3	3	3	4	4	4	4	5	5	5	5
N	4	6	6	6	6	8	8	8	8	10	10	10	10	12	12	12	12	14	14	14	14	16	16	16	16
KG	9.53	10.3	11.07	11.84	12.61	13.38	14.15	14.92	15.69	16.47	17.24	18.01	18.78	19.55	20.32	21.09	21.86	22.63	23.4	24.18	24.95	25.72	26.49	27.26	28.03

應用例  
Application

一般 / 螺桿仕様  
ETH Series

一般 / 皮帶仕様  
ETB / M

無塵 / 螺桿仕様  
GCH / ECH

無塵 / 皮帶仕様  
ECB

直交連結  
XYGT / XYTH / XYTB

參考資料  
Reference

單軸  
1 axis  
ETH

ETH13

ETH14

ETH17

ETH22

ETH17M

ETH22M

# ETH22 單軸 / 1-axis

▶ 螺桿驅動  
Ball Screw Drive



精度 ↑  
±0.005 mm

此圖僅供參考，出貨規格詳見尺寸圖面  
The picture is just for the reference. Please check the actual dimensions on the drawing.

- 最大行程 Maximum Stroke **1500mm**
- 最高速度 Maximum Speed **2000mm/s**
- 馬達容量 Motor output **750W**
- 滾珠螺桿 Ball Screw **Ø25mm**
- 直線滑軌 Linear Guide **23X18-2 支**

## 型號表示方式 Ordering Method

# ETH22 - L10 - 50 - M - M75B - C 4 - 0001

本體型號  
Model

行程  
Stroke  
50-1500mm  
50間隔 50 mm Pitch

特注式樣  
Special Order No.

螺桿導程  
Ball Screw Lead

5	5mm
10	10mm
25	25mm
40	40mm

馬達位置  
Motor Position

M	馬達直結 Motor Hidden In
BC	馬達外露 Motor Exposed
BL	馬達左折 Motor Left Side
BR	馬達右折 Motor Right Side
BM	馬達下折 Motor Bottom Side

馬達廠牌  
Motor Brand

M	三菱 Mitsubishi	10	-	B
P	國際 Panasonic	20	-	
Y	安川 Yaskawa	40	-	
T	台達 Delta	75	750W	

\*若無煞車則不表示。\* If No Brake, No Description.

原點感應器  
Home Sensor

內置型 In Side	
A	馬達側 Motor Side
B	反馬達側 Opposite Motor Side
外掛型 Out Side	
C	馬達側 Motor Side
D	反馬達側 Opposite Motor Side
	無 SENSOR No Sensor
E	無 SENSOR No Sensor

端點極限感應器  
Limit Sensor

內置型 In Side	
1	1只 1 Pc
2	2只 2 Pc
外掛型 Out Side	
3	1只 1 Pc
4	2只 2 Pc
	無 SENSOR No Sensor
5	無 SENSOR No Sensor

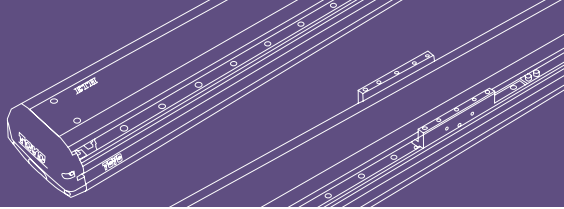

應用例  
Application

一般 / 螺桿仕様  
ETH Series

一般 / 皮帶仕様  
ETB / M

無塵 / 螺桿仕様  
GCH / ECH

無塵 / 皮帶仕様  
ECB

直交連結  
XYGT / XYTH / XYTB

參考資料  
Reference

基本仕様 Specification

規格 Spec	位置重複精度 Repeatability (mm)	±0.005				
	螺桿導程 Ball Screw Lead (mm)	5	10	25	40	
	最高速度 Maximum Speed (mm/s) ※1	250	500	1250	2000	
	最大可搬重量 Maximum Payload	水平使用 Horizontal (kg)	150	150	105	43
		垂直使用 Vertical (kg)	55	45	20	12
	定格推力 Rated Thrust (N)	2563 1281 640 320				
標準行程 Stroke Pitch (mm) ※2	50-1500mm/50 間隔 50 mm Pitch					
部品 Parts	AC 伺服馬達容量 AC Servo Motor Output (W)	750				
	滾珠螺桿外徑 Ball Screw Ø (mm)	C7Ø25		C7Ø20		
	高剛性直線滑軌, High Rigidity Linear Guide (mm)	W23XH18				
	連軸器 Coupling (mm)	17X19		12X19		
	原點感應器 Home Sensor	外掛 Outside	EE-SX672(NPN)			
	內置 Built-In	EE-SX674(NPN)				

※1 馬達加減速設定 0.2 秒。  
Acceleration and deceleration value is set 0.2 second.  
※2 行程超過 900 時，會產生螺桿偏擺，此時請將速度調降。  
When the stroke is over 900mm, the run-out of the ballscrew will occur. We recommend to low down the working speed under this circumstances.

感應器接線圖 < 原點及端點 > Sensor Layout

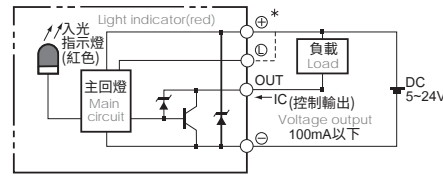

容許負載力距表 Allowable Overhang

水平安裝 Horizontal Installation				壁掛安裝 Wall Installation				垂直安裝 Vertical Installation			
導程 Lead	A	B	C	導程 Lead	A	B	C	導程 Lead	A	C	
5	100kg	5000	633	557	110kg	500	569	4500	30kg	2355	2355
	125kg	3880	491	431	130kg	412	469	3711	40kg	1768	1768
	150kg	3357	396	347	150kg	347	396	3357	55kg	1288	1288
10	100kg	3220	563	474	110kg	427	503	2900	25kg	2505	2505
	125kg	2554	434	367	130kg	351	414	2444	35kg	1795	1795
	150kg	2113	349	295	150kg	295	349	2113	45kg	1396	1396
25	65kg	1522	614	458	70kg	420	564	1404	15kg	2711	2711
	85kg	1136	451	336	90kg	315	420	1066	20kg	2033	2033
	105kg	893	350	262	105kg	262	350	893	-	-	-
40	18kg	2445	1616	1052	15kg	1272	1955	2948	7kg	3511	3511
	30kg	1436	938	613	24kg	778	1190	1813	12kg	2055	2055
	43kg	978	630	412	43kg	412	630	978	-	-	-

靜態容許負載慣量 Static Loading Moment

MY	MP	MR
2052	2052	1810

\* 力距表所表示的數據，代表重心。  
The torque value in the chart indicate the center of gravity.  
\* 符合型錄規範的正常使用下，保證壽命為 10000 公里。  
Operation life is 10,000km when the product is using under the specified conditions.  
\* 倒吊使用無法套用標準規範，如有需求請洽詢我業務。  
Data information is not for ceiling-mount inverse use.  
Contact us for the details if you want to apply ceiling-mount inverse usage.

搭配伺服馬達一覽表 Suitable Motor Brand

廠牌 Brand	馬達記號 Mark	煞車有無 Brake	馬達容量 Watt	電源電壓 AC-Voltage	伺服馬達型號 Motor Model	驅動器型號 Driver Model
三菱 Mitsubishi	M	無煞車 (水平仕様) No Brake (Horizontal Type)	750	220	HG-KR73	MR-J4-70A
		有煞車 (垂直仕様) With Brake (Vertical Type)	750	220	HG-KR73B	MR-J4-70A
國際 Panasonic	P	無煞車 (水平仕様) No Brake (Horizontal Type)	750	220	MHMD082G1U	MCDHT3520
		有煞車 (垂直仕様) With Brake (Vertical Type)	750	220	MHMD082G1V	MCDHT3520
台達 Delta	T	無煞車 (水平仕様) No Brake (Horizontal Type)	750	220	ECMA-C20807ES	ASD-B20721-B
		有煞車 (垂直仕様) With Brake (Vertical Type)	750	220	ECMA-C20807FS	ASD-B20721-B

單軸  
1 axis  
ETH

ETH13

ETH14

ETH17

ETH22

ETH17M

ETH22M

## 馬達直結 / 馬達外露

Motor Hidden In / Motor Exposed

M

馬達直結 Motor Hidden In



Download CAD data at [www.toyorobot.com](http://www.toyorobot.com)

單位 Unit : mm

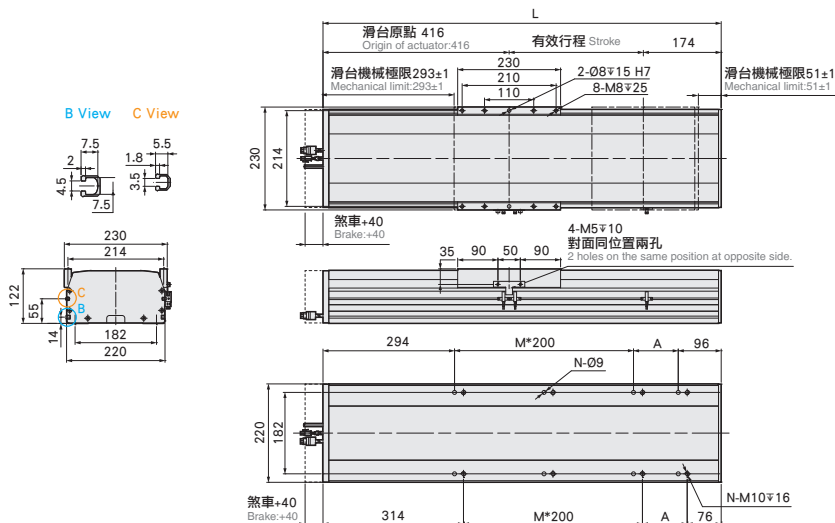

有效行程 Stroke	50	100	150	200	250	300	350	400	450	500	550	600	650	700	750	800	850	900	950	1000	1050	1100	1150	1200	1250	1300	1350	1400	1450	1500
L	640	690	740	790	840	890	940	990	1040	1090	1140	1190	1240	1290	1340	1390	1440	1490	1540	1590	1640	1690	1740	1790	1840	1890	1940	1990	2040	2090
A	50	100	150	200	50	100	150	200	50	100	150	200	50	100	150	200	50	100	150	200	50	100	150	200	50	100	150	200	50	100
M	1	1	1	1	2	2	2	2	3	3	3	3	4	4	4	4	5	5	5	5	6	6	6	6	7	7	7	7	8	8
N	6	6	6	6	8	8	8	8	10	10	10	10	12	12	12	12	14	14	14	14	16	16	16	16	18	18	18	18	20	20
KG	27.85	29.32	30.79	32.26	33.73	35.2	36.67	38.14	39.61	41.08	42.55	44.02	45.49	46.96	48.43	49.9	51.37	52.84	54.31	55.78	57.25	58.72	60.19	61.66	63.13	64.6	66.07	67.54	69.01	70.48

BC

馬達外露 Motor Exposed



Download CAD data at [www.toyorobot.com](http://www.toyorobot.com)

單位 Unit : mm

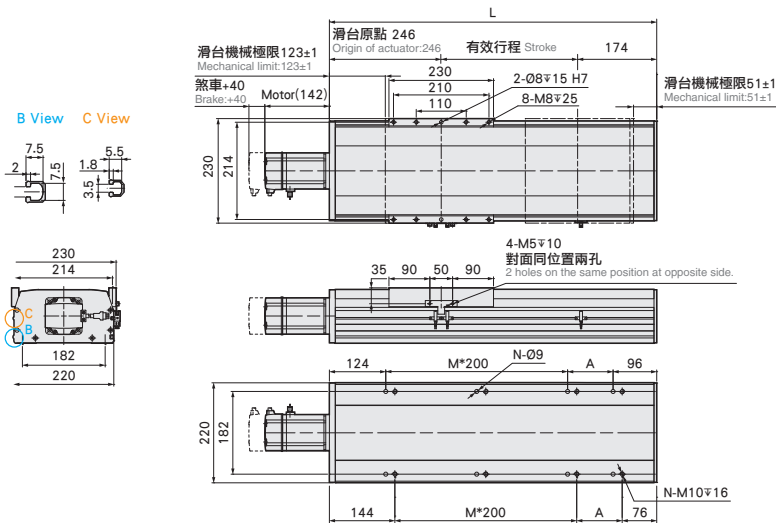

有效行程 Stroke	50	100	150	200	250	300	350	400	450	500	550	600	650	700	750	800	850	900	950	1000	1050	1100	1150	1200	1250	1300	1350	1400	1450	1500
L	470	520	570	620	670	720	770	820	870	920	970	1020	1070	1120	1170	1220	1270	1320	1370	1420	1470	1520	1570	1620	1670	1720	1770	1820	1870	1920
A	50	100	150	200	50	100	150	200	50	100	150	200	50	100	150	200	50	100	150	200	50	100	150	200	50	100	150	200	50	100
M	1	1	1	1	2	2	2	2	3	3	3	3	4	4	4	4	5	5	5	5	6	6	6	6	7	7	7	7	8	8
N	6	6	6	6	8	8	8	8	10	10	10	10	12	12	12	12	14	14	14	14	16	16	16	16	18	18	18	18	20	20
KG	25.4	26.86	28.32	29.78	31.24	32.7	34.16	35.62	37.08	38.54	40	41.46	42.92	44.38	45.84	47.3	48.76	50.22	51.68	53.14	54.6	56.06	57.52	58.98	60.44	61.9	63.36	64.82	66.28	67.74



# 馬達左折 / 馬達右折

## Motor Left Side / Motor Right Side

**BL 馬達左折 Motor Left Side**   [Download CAD data at www.toyorobot.com](http://www.toyorobot.com)

單位 Unit : mm

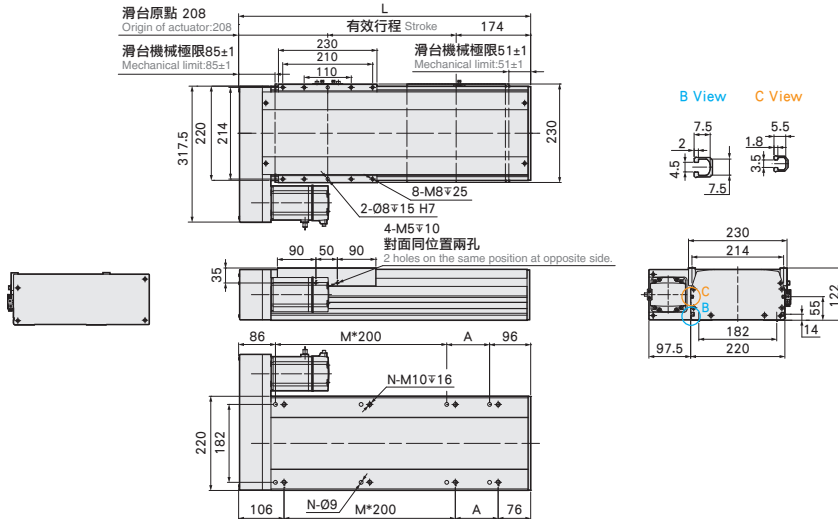

有效行程 Stroke	50	100	150	200	250	300	350	400	450	500	550	600	650	700	750	800	850	900	950	1000	1050	1100	1150	1200	1250	1300	1350	1400	1450	1500
L	432	482	532	582	632	682	732	782	832	882	932	982	1032	1082	1132	1182	1232	1282	1332	1382	1432	1482	1532	1582	1632	1682	1732	1782	1832	1882
A	50	100	150	200	50	100	150	200	50	100	150	200	50	100	150	200	50	100	150	200	50	100	150	200	50	100	150	200	50	100
M	1	1	1	1	2	2	2	2	3	3	3	3	4	4	4	4	5	5	5	5	5	6	6	6	7	7	7	7	8	8
N	6	6	6	6	8	8	8	8	10	10	10	10	12	12	12	12	14	14	14	14	14	16	16	16	18	18	18	18	20	20
KG	24.2	25.66	27.12	28.58	30.04	31.5	32.96	34.42	35.88	37.34	38.8	40.26	41.72	43.18	44.64	46.1	47.56	49.02	50.48	51.94	53.4	54.86	56.32	57.78	59.24	60.7	62.16	63.62	65.08	66.54

**BR 馬達右折 Motor Right Side**   [Download CAD data at www.toyorobot.com](http://www.toyorobot.com)

單位 Unit : mm

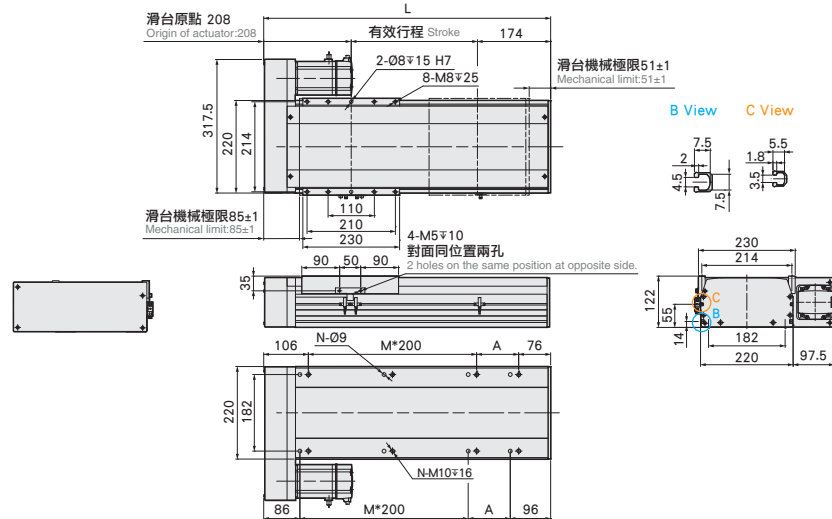

有效行程 Stroke	50	100	150	200	250	300	350	400	450	500	550	600	650	700	750	800	850	900	950	1000	1050	1100	1150	1200	1250	1300	1350	1400	1450	1500
L	432	482	532	582	632	682	732	782	832	882	932	982	1032	1082	1132	1182	1232	1282	1332	1382	1432	1482	1532	1582	1632	1682	1732	1782	1832	1882
A	50	100	150	200	50	100	150	200	50	100	150	200	50	100	150	200	50	100	150	200	50	100	150	200	50	100	150	200	50	100
M	1	1	1	1	2	2	2	2	3	3	3	3	4	4	4	4	5	5	5	5	5	6	6	6	7	7	7	7	8	8
N	6	6	6	6	8	8	8	8	10	10	10	10	12	12	12	12	14	14	14	14	14	16	16	16	18	18	18	18	20	20
KG	24.2	25.66	27.12	28.58	30.04	31.5	32.96	34.42	35.88	37.34	38.8	40.26	41.72	43.18	44.64	46.1	47.56	49.02	50.48	51.94	53.4	54.86	56.32	57.78	59.24	60.7	62.16	63.62	65.08	66.54

應用例  
Application

一般 / 螺桿仕様  
ETH Series

一般 / 皮帶仕様  
ETB / M

無塵 / 螺桿仕様  
GCH / ECH

無塵 / 皮帶仕様  
ECB

直交連結  
XYG / XJH / XYTB

參考資料  
Reference

單軸  
1 axis  
ETH

ETH13

ETH14

ETH17

ETH22

ETH17M

ETH22M

## 馬達下折

Motor Bottom Side

單位 Unit : mm

BM 馬達下折 Motor Bottom Side   [Download CAD data at www.toyorobot.com](http://www.toyorobot.com)

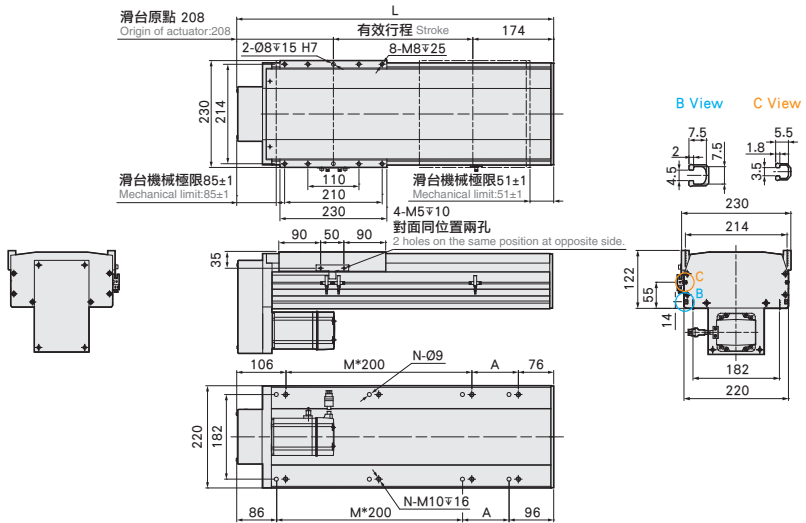

有效行程 Stroke	50	100	150	200	250	300	350	400	450	500	550	600	650	700	750	800	850	900	950	1000	1050	1100	1150	1200	1250	1300	1350	1400	1450	1500
L	432	482	532	582	632	682	732	782	832	882	932	982	1032	1082	1132	1182	1232	1282	1332	1382	1432	1482	1532	1582	1632	1682	1732	1782	1832	1882
A	50	100	150	200	50	100	150	200	50	100	150	200	50	100	150	200	50	100	150	200	50	100	150	200	50	100	150	200	50	100
M	1	1	1	1	2	2	2	3	3	3	3	4	4	4	4	5	5	5	5	6	6	6	6	7	7	7	7	8	8	
N	6	6	6	6	8	8	8	10	10	10	10	12	12	12	12	14	14	14	14	16	16	16	16	18	18	18	18	20	20	
KG	24.2	25.66	27.12	28.58	30.04	31.5	32.96	34.42	35.88	37.34	38.8	40.26	41.72	43.18	44.64	46.1	47.56	49.02	50.48	51.94	53.4	54.86	56.32	57.78	59.24	60.7	62.16	63.62	65.08	66.54

免費服務專線：大陸 400-875-0009 台灣 0800-800-893  
Toll-free Number China Taiwan

應用例  
Application

一般 / 標準仕様  
ETH Series

一般 / 皮帶仕様  
ETB / M

無塵 / 標準仕様  
GCH / ECH

無塵 / 皮帶仕様  
ECB

直交連結  
XYGT / XYTH / XYTB

參考資料  
Reference

單軸  
1 axis  
**ETH**

ETH13

ETH14

ETH17

ETH22

ETH17M

ETH22M

# MEMO

MEMO

# ETH17M 單軸 / 1-axis

▶ 長行程 ▶ 螺桿驅動  
Long Stroke ▶ Ball Screw Drive

精度  
±0.005 mm



◎可對應無塵規格。  
Customizable for clean room type.

此圖僅供參考，出貨規格詳見尺寸圖面  
The picture is just for the reference. Please check the actual dimensions on the drawing.

最大行程 Maximum Stroke **2200mm**    最高速度 Maximum Speed **1280mm/s**    馬達容量 Motor output **400W**    滾珠螺桿 Ball Screw **Ø16mm**    直線滑軌 Linear Guide **15X12.5-2 支**

\*馬達最高轉速：2400rpm\*  
\*Maximum motor speed: 2400rpm.

## 型號表示方式 Ordering Method

# ETH17M - L5 - 800 - M - M40B - C 4 - 0001

本體型號  
Model

行程  
Stroke  
800-2200mm  
50間隔 50 mm Pitch

特注式樣  
Special Order No.

螺桿導程  
Ball Screw Lead

5	5mm
10	10mm
20	20mm
32	32mm

馬達位置  
Motor Position

M	馬達直結 Motor Hidden In
BC	馬達外露 Motor Exposed
BL	馬達左折 Motor Left Side
BR	馬達右折 Motor Right Side
BM	馬達下折 Motor Bottom Side

馬達廠牌  
Motor Brand

M	三菱 Mitsubishi	10	-	B
P	國際 Panasonic	20	-	
Y	安川 Yaskawa	40	400W	
T	台達 Delta	75	-	

\*若無煞車則不表示。\* If No Brake, No Description.

原點感應器  
Home Sensor

外掛型 Out Side	
C	馬達側 Motor Side
D	反馬達側 Opposite Motor Side
	無 SENSOR No Sensor
E	無 SENSOR No Sensor

端點極限感應器  
Limit Sensor

外掛型 Out Side	
3	1只 1 Pc
4	2只 2 Pc
	無 SENSOR No Sensor
5	無 SENSOR No Sensor

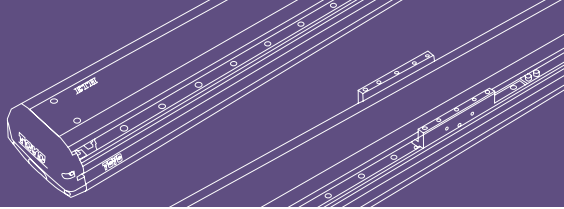

應用例  
Application

一般 / 螺桿仕様  
ETH Series

一般 / 皮帶仕様  
ETB / M

無塵 / 螺桿仕様  
GCH / ECH

無塵 / 皮帶仕様  
ECB

直交連結  
XYGT / XYTH / XYTB

參考資料  
Reference

基本仕様 Specification

規格 Spec	位置重複精度 Repeatability (mm)	±0.005				
	螺桿導程 Ball Screw Lead (mm)	5	10	20	32	
	最高速度 Maximum Speed (mm/s) ※1	200	400	800	1280	
	最大可搬重量 Maximum Payload	水平使用 Horizontal (kg)	110	90	40	30
		垂直使用 Vertical (kg)	33	22	10	8
	定格推力 Rated Thrust (N)	1388	694	347	218	
標準行程 Stroke Pitch (mm) ※2	800-2200mm/50 間隔 50 mm Pitch					
部品 Parts	AC 伺服馬達容量 AC Servo Motor Output (W) ※3	400				
	滾珠螺桿外徑 Ball Screw Ø (mm)	C7Ø16				
	高剛性直線滑軌 High Rigidity Linear Guide (mm)	W15XH12.5				
	連軸器 Coupling (mm)	10X14				
	原點感應器 Home Sensor	外掛 Outside	EE-SX672(NPN)			

※1 馬速加減速設定 0.2 秒。  
 Acceleration and deceleration value is set 0.2 second.  
 ※2 行程超過 1600 時，會產生螺桿偏擺，此時請將速度調降。  
 When the stroke is over 1600mm, the run-out of the ballscrew will occur. We recommend to low down the working speed under this circumstances.  
 ※3 馬速最高轉速：2400rpm。Maximum motor speed: 2400rpm.

感應器接線圖 < 原點及端點 > Sensor Layout

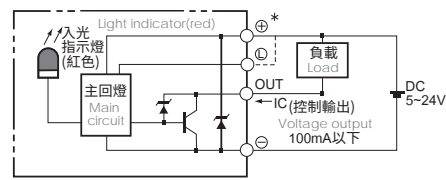

容許負載力距表 Allowable Overhang

水平安裝 Horizontal Installation				壁掛安裝 Wall Installation				垂直安裝 Vertical Installation			
	A	B	C		A	B	C		A	C	
導程 5 Lead	70kg	2092	162	208	75kg	190	148	1911	15kg	940	940
	90kg	1555	117	149	95kg	140	108	1450	22kg	640	640
	110kg	1210	88	113	110kg	113	88	1210	33kg	427	427
導程 10 Lead	60kg	1107	172	208	65kg	188	156	1008	10kg	1248	1248
	75kg	848	130	156	80kg	144	119	788	14kg	894	894
	90kg	680	101	122	90kg	122	101	680	22kg	569	569
導程 20 Lead	20kg	1498	491	520	25kg	408	382	1180	7kg	1417	1417
	30kg	973	313	334	35kg	280	262	825	10kg	993	993
	40kg	712	225	238	40kg	238	225	712	-	-	-
導程 32 Lead	10kg	1311	692	625	15kg	408	449	860	5kg	1255	1255
	20kg	633	326	295	25kg	230	252	495	8kg	785	785
	30kg	405	203	187	30kg	187	203	405	-	-	-

靜態容許負載價量 Static Loading Moment

	MY	MP	MR
MY	552		
MP		552	
MR			638

\* 力距表所表示的數據，代表重心。  
 The torque value in the chart indicate the center of gravity.  
 \* 符合型錄規範的正常使用下，保證壽命為 10000 公里。  
 Operation life is 10,000km when the product is using under the specified conditions.  
 \* 倒吊使用無法套用標準規範，如有需求請洽詢我司業務。  
 Data information is not for ceiling-mount inverse use.  
 Contact us for the details if you want to apply ceiling-mount inverse usage.

搭配伺服馬達一覽表 Suitable Motor Brand

廠牌 Brand	馬達記號 Mark	煞車有無 Brake	馬達容量 Watt	電源電壓 AC-Voltage	伺服馬達型號 Motor Model	驅動器型號 Driver Model
三菱 Mitsubishi	M	無煞車 (水平仕様) No Brake (Horizontal Type)	400	220	HG-KR43	MR-J4-40A
		有煞車 (垂直仕様) With Brake (Vertical Type)	400	220	HG-KR43B	MR-J4-40A
國際 Panasonic	P	無煞車 (水平仕様) No Brake (Horizontal Type)	400	220	MHMD042G1U	MBDHT2510
		有煞車 (垂直仕様) With Brake (Vertical Type)	400	220	MHMD042G1V	MBDHT2510
台達 Delta	T	無煞車 (水平仕様) No Brake (Horizontal Type)	400	220	ECMA-C20604ES	ASD-B20421-B
		有煞車 (垂直仕様) With Brake (Vertical Type)	400	220	ECMA-C20604FS	ASD-B20421-B

單軸  
1 axis  
ETH

ETH13

ETH14

ETH17

ETH22

ETH17M

ETH22M

## 馬達直結 / 馬達外露

Motor Hidden In / Motor Exposed

### M 馬達直結 Motor Hidden In



Download CAD data at [www.toyorobot.com](http://www.toyorobot.com)

單位 Unit : mm

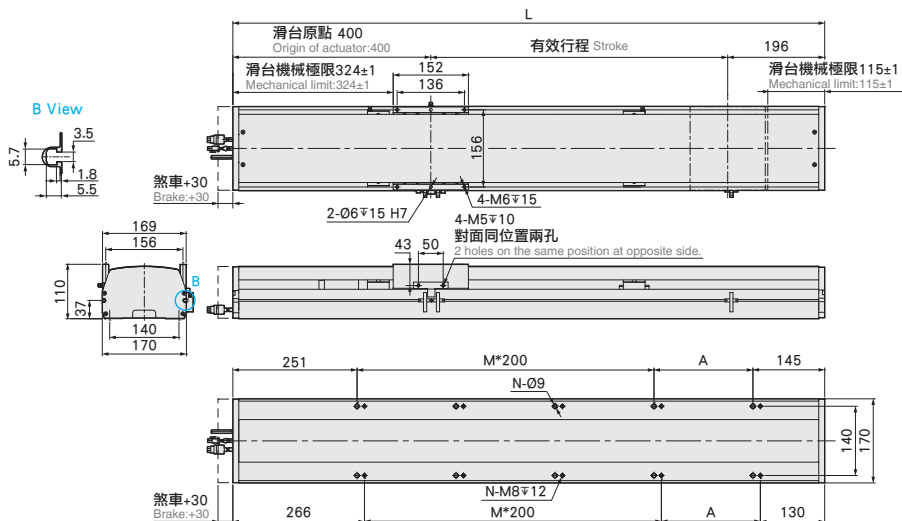

有效行程 Stroke	800	850	900	950	1000	1050	1100	1150	1200	1250	1300	1350	1400	1450	1500	1550	1600	1650	1700	1750	1800	1850	1900	1950	2000	2050	2100	2150	2200
L	1396	1446	1496	1546	1596	1646	1696	1746	1796	1846	1896	1946	1996	2046	2096	2146	2196	2246	2296	2346	2396	2446	2496	2546	2596	2646	2696	2746	2796
A	200	50	100	150	200	50	100	150	200	50	100	150	200	50	100	150	200	50	100	150	200	50	100	150	200	50	100	150	200
M	4	5	5	5	5	6	6	6	6	7	7	7	7	8	8	8	8	9	9	9	9	9	10	10	10	10	11	11	11
N	12	14	14	14	14	16	16	16	16	18	18	18	18	20	20	20	22	22	22	22	22	24	24	24	24	26	26	26	26
KG	28.88	30.56	31.24	31.92	32.6	33.28	33.96	34.64	35.32	36	36.68	37.36	38.04	38.72	39.4	40.08	40.76	41.44	42.12	42.8	43.48	44.16	44.84	45.52	46.2	46.88	47.56	48.24	48.92

### BC 馬達外露 Motor Exposed



Download CAD data at [www.toyorobot.com](http://www.toyorobot.com)

單位 Unit : mm

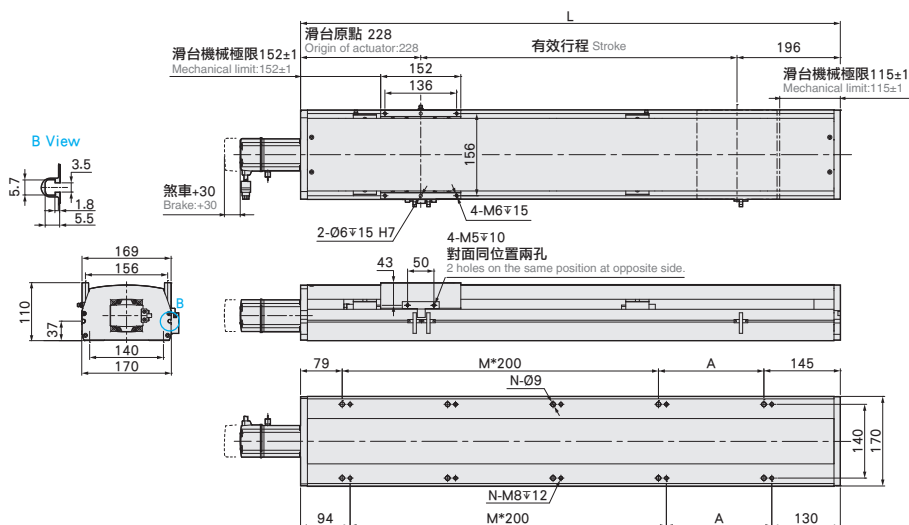

有效行程 Stroke	800	850	900	950	1000	1050	1100	1150	1200	1250	1300	1350	1400	1450	1500	1550	1600	1650	1700	1750	1800	1850	1900	1950	2000	2050	2100	2150	2200
L	1224	1274	1324	1374	1424	1474	1524	1574	1624	1674	1724	1774	1824	1874	1924	1974	2024	2074	2124	2174	2224	2274	2324	2374	2424	2474	2524	2574	2624
A	200	50	100	150	200	50	100	150	200	50	100	150	200	50	100	150	200	50	100	150	200	50	100	150	200	50	100	150	200
M	4	5	5	5	5	6	6	6	6	7	7	7	7	8	8	8	8	9	9	9	9	9	10	10	10	10	11	11	11
N	12	14	14	14	14	16	16	16	16	18	18	18	18	20	20	20	22	22	22	22	22	24	24	24	24	26	26	26	26
KG	28.99	29.67	30.35	31.03	31.71	32.39	33.07	33.75	34.43	35.11	35.79	36.47	37.15	37.83	38.51	39.19	39.87	40.55	41.23	41.91	42.59	43.27	43.95	44.63	45.31	45.99	46.67	47.35	48.03

# 馬達左折 / 馬達右折

## Motor Left Side / Motor Right Side

### BL 馬達左折 Motor Left Side

單位 Unit : mm

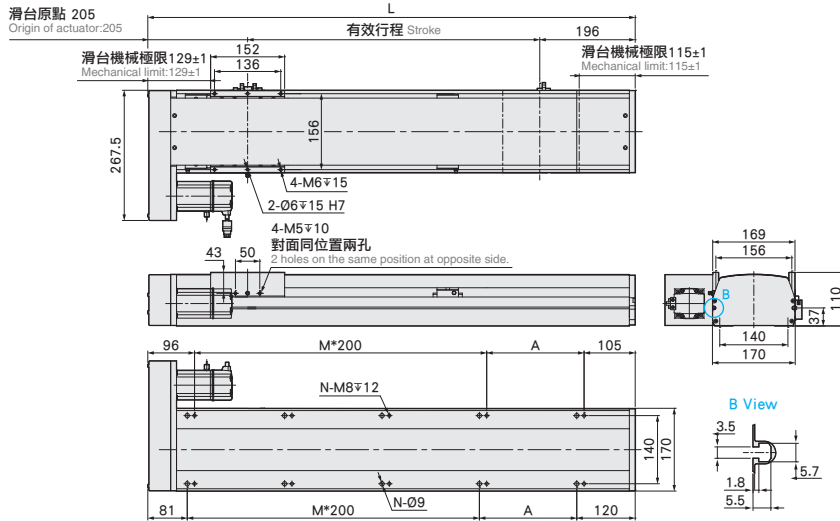

有效行程 Stroke	800	850	900	950	1000	1050	1100	1150	1200	1250	1300	1350	1400	1450	1500	1550	1600	1650	1700	1750	1800	1850	1900	1950	2000	2050	2100	2150	2200
L	1201	1251	1301	1351	1401	1451	1501	1551	1601	1651	1701	1751	1801	1851	1901	1951	2001	2051	2101	2151	2201	2251	2301	2351	2401	2451	2501	2551	2601
A	200	50	100	150	200	50	100	150	200	50	100	150	200	50	100	150	200	50	100	150	200	50	100	150	200	50	100	150	200
M	4	5	5	5	5	6	6	6	6	7	7	7	7	8	8	8	8	9	9	9	9	10	10	10	10	11	11	11	11
N	12	14	14	14	14	16	16	16	16	18	18	18	18	20	20	20	20	22	22	22	22	24	24	24	24	26	26	26	26
KG	29.86	30.54	31.22	31.9	32.58	33.26	33.94	34.62	35.3	35.98	36.66	37.34	38.02	38.7	39.38	40.06	40.74	41.42	42.1	42.78	43.46	44.14	44.82	45.5	46.18	46.86	47.54	48.22	48.9

### BR 馬達右折 Motor Right Side

單位 Unit : mm

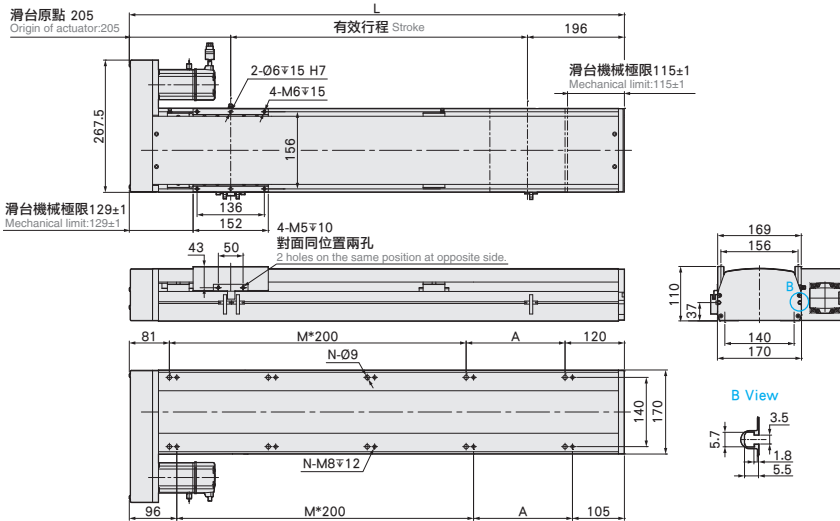

有效行程 Stroke	800	850	900	950	1000	1050	1100	1150	1200	1250	1300	1350	1400	1450	1500	1550	1600	1650	1700	1750	1800	1850	1900	1950	2000	2050	2100	2150	2200
L	1201	1251	1301	1351	1401	1451	1501	1551	1601	1651	1701	1751	1801	1851	1901	1951	2001	2051	2101	2151	2201	2251	2301	2351	2401	2451	2501	2551	2601
A	200	50	100	150	200	50	100	150	200	50	100	150	200	50	100	150	200	50	100	150	200	50	100	150	200	50	100	150	200
M	4	5	5	5	5	6	6	6	6	7	7	7	7	8	8	8	8	9	9	9	9	10	10	10	10	11	11	11	11
N	12	14	14	14	14	16	16	16	16	18	18	18	18	20	20	20	20	22	22	22	22	24	24	24	24	26	26	26	26
KG	29.86	30.54	31.22	31.9	32.58	33.26	33.94	34.62	35.3	35.98	36.66	37.34	38.02	38.7	39.38	40.06	40.74	41.42	42.1	42.78	43.46	44.14	44.82	45.5	46.18	46.86	47.54	48.22	48.9

應用例  
Application

一般 / 螺桿仕樣  
ETH Series

一般 / 皮帶仕樣  
ETB / M

無塵 / 螺桿仕樣  
GCH / ECH

無塵 / 皮帶仕樣  
ECB

直交連結  
XYGT / XYTH / XYTB

參考資料  
Reference

單軌  
1 axis  
ETH

ETH13

ETH14

ETH17

ETH22

ETH17M

ETH22M

## 馬達下折

### Motor Bottom Side

BM 馬達下折 Motor Bottom Side   [Download CAD data at www.toyorobot.com](http://www.toyorobot.com)

單位 Unit : mm

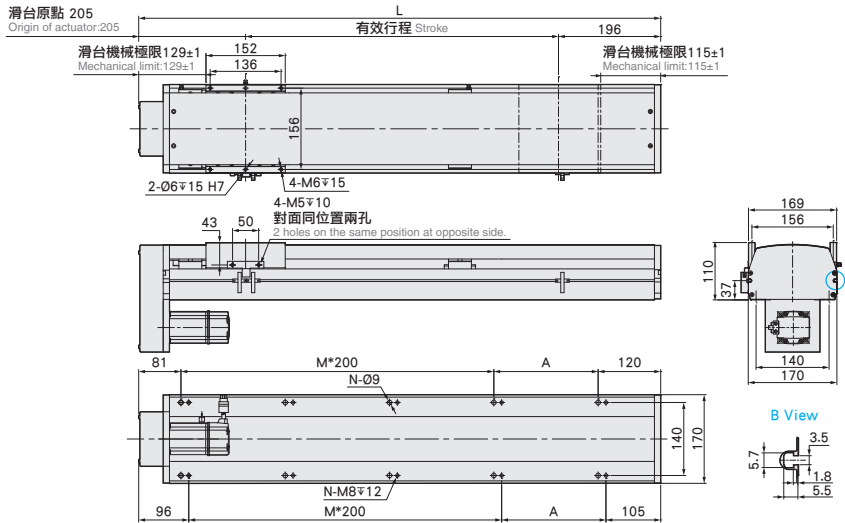

有效行程 Stroke	800	850	900	950	1000	1050	1100	1150	1200	1250	1300	1350	1400	1450	1500	1550	1600	1650	1700	1750	1800	1850	1900	1950	2000	2050	2100	2150	2200	
L	1201	1251	1301	1351	1401	1451	1501	1551	1601	1651	1701	1751	1801	1851	1901	1951	2001	2051	2101	2151	2201	2251	2301	2351	2401	2451	2501	2551	2601	
A	200	50	100	150	200	50	100	150	200	50	100	150	200	50	100	150	200	50	100	150	200	50	100	150	200	50	100	150	200	
M	4	5	5	5	5	6	6	6	6	7	7	7	7	8	8	8	8	9	9	9	9	10	10	10	10	11	11	11	11	
N	12	14	14	14	14	16	16	16	16	18	18	18	18	20	20	20	20	22	22	22	22	24	24	24	24	24	26	26	26	26
KG	29.86	30.54	31.22	31.9	32.58	33.26	33.94	34.62	35.3	35.98	36.66	37.34	38.02	38.7	39.38	40.06	40.74	41.42	42.1	42.78	43.46	44.14	44.82	45.5	46.18	46.86	47.54	48.22	48.9	



免費服務專線：大陸 400-875-0009 台灣 0800-800-893  
Toll-free Number China Taiwan

# MEMO

應用例  
Application

一般 / 標準仕様  
ETH Series

一般 / 皮帶仕様  
ETB / M

無塵 / 標準仕様  
GCH / ECH

無塵 / 皮帶仕様  
ECB

直交連結  
XYGT / XYTH / XYTB

參考資料  
Reference

單軸  
1 axis  
**ETH**

ETH13

ETH14

ETH17

ETH22

ETH17M

ETH22M

# ETH17M 單軸 / 1-axis

▶ 長行程 ▶ 螺桿驅動  
Long Stroke ▶ Ball Screw Drive

精度  
±0.005 mm



◎可對應無塵規格。  
Customizable for clean room type.

此圖僅供參考，出貨規格詳見尺寸圖面  
The picture is just for the reference. Please check the actual dimensions on the drawing.

最大行程 Maximum Stroke **2200mm**    最高速度 Maximum Speed **1280mm/s**    馬達容量 Motor output **750W**    滾珠螺桿 Ball Screw **Ø16mm**    直線滑軌 Linear Guide **15X12.5-2 支**

※ 馬達最高轉速：2400rpm。  
※ Maximum motor speed: 2400rpm.

## 型號表示方式 Ordering Method

# ETH17M - L 5 - 800 - BC - M75B - C 4 - 0001

本體型號  
Model

特注式樣  
Special Order No.

行程  
Stroke  
800-2200mm  
50間隔 50 mm Pitch

螺桿導程  
Ball Screw Lead

5	5mm
10	10mm
20	20mm
32	32mm

馬達位置  
Motor Position

BC	馬達外露 Motor Exposed
BM	馬達下折 Motor Bottom Side
BL	馬達左折 Motor Left Side
BR	馬達右折 Motor Right Side

馬達廠牌  
Motor Brand

M	三菱 Mitsubishi	10	-	B
P	國際 Panasonic	20	-	
Y	安川 Yaskawa	40	-	
T	台達 Delta	75	750W	

\*若無煞車則不表示。\* If No Brake, No Description.

原點感應器  
Home Sensor

外掛型 Out Side	
C	馬達側 Motor Side
D	反馬達側 Opposite Motor Side
	無 SENSOR No Sensor
E	無 SENSOR No Sensor

端點極限感應器  
Limit Sensor

外掛型 Out Side	
3	1只 1 Pc
4	2只 2 Pc
	無 SENSOR No Sensor
5	無 SENSOR No Sensor

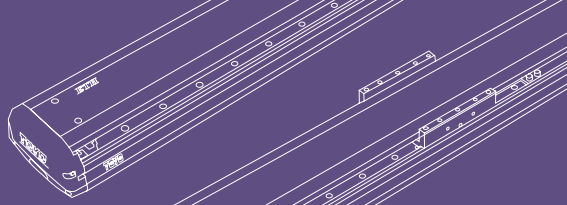

**基本仕様 Specification**

規格 Spec	位置重複精度 Repeatability (mm)	±0.005				
	螺桿導程 Ball Screw Lead (mm)	5	10	20	32	
	最高速度 Maximum Speed (mm/s) ※1	200	400	800	1280	
	最大可搬重量 Maximum Payload	水平使用 Horizontal (kg)	120	95	50	35
		垂直使用 Vertical (kg)	40	25	15	12
	定格推力 Rated Thrust (N)	2563	1281	640	400	
標準行程 Stroke Pitch (mm) ※2	800-2200mm/50 間隔 50 mm Pitch					
部品 Parts	AC 伺服馬達容量 AC Servo Motor Output (W) ※3	750				
	滾珠螺桿外徑 Ball Screw Ø (mm)	C7Ø16				
	高剛性直線滑軌, High Rigidity Linear Guide (mm)	W15XH12.5				
	連軸器 Coupling (mm)	10X19				
	原點感應器 Home Sensor	外掛 Outside	EE-SX672(NPN)			

※1 馬達加減速設定 0.2 秒。  
 Acceleration and deceleration value is set 0.2 second.  
 ※2 行程超過 1600 時，會產生螺桿偏擺，此時請將速度調降。  
 When the stroke is over 1600mm, the run-out of the ballscrew will occur. We recommend to low down the working speed under this circumstances.  
 ※3 馬達最高轉速：2400rpm。Maximum motor speed: 2400rpm.

**容許負載力距表 Allowable Overhang**

水平安裝 Horizontal Installation				壁掛安裝 Wall Installation				垂直安裝 Vertical Installation			
	A	B	C		A	B	C		A	C	
導程 5 Lead	70kg	2092	162	208	75kg	190	148	1911	15kg	940	940
	90kg	1555	117	149	95kg	140	108	1450	22kg	640	640
	120kg	1080	78	100	120kg	100	78	1080	40kg	350	350
導程 10 Lead	60kg	1107	172	208	65kg	188	156	1008	10kg	1248	1248
	75kg	848	130	156	80kg	144	119	788	14kg	894	894
	95kg	637	94	114	95kg	114	94	637	25kg	499	499
導程 20 Lead	20kg	1498	491	520	25kg	408	382	1180	7kg	1417	1417
	30kg	973	313	334	35kg	280	262	825	10kg	993	993
	50kg	550	172	182	50kg	182	172	550	15kg	660	660
導程 32 Lead	10kg	1311	692	625	15kg	408	449	860	5kg	1255	1255
	20kg	633	326	295	25kg	230	252	495	8kg	785	785
	35kg	339	169	156	35kg	156	169	339	12kg	525	525

**靜態容許負載價量 Static Loading Moment**

	靜態容許負載價量 (單位 Unit: N.m)
MY	552
MP	552
MR	638

\* 力距表所表示的數據，代表重心。  
 The torque value in the chart indicate the center of gravity.  
 \* 符合型錄規範的正常使用下，保證壽命為 10000 公里。  
 Operation life is 10,000km when the product is using under the specified conditions.  
 \* 倒吊使用無法套用標準規範，如有需求請洽詢我司業務。  
 Data information is not for ceiling-mount inverse use.  
 Contact us for the details if you want to apply ceiling-mount inverse usage.

**搭配伺服馬達一覽表 Suitable Motor Brand**

廠牌 Brand	馬達記號 Mark	煞車有無 Brake	馬達容量 Watt	電源電壓 AC-Voltage	伺服馬達型號 Motor Model	驅動器型號 Driver Model
三菱 Mitsubishi	M	無煞車 (水平仕様) No Brake (Horizontal Type)	750	220	HG-KR73	MR-J4-70A
		有煞車 (垂直仕様) With Brake (Vertical Type)	750	220	HG-KR73B	MR-J4-70A
國際 Panasonic	P	無煞車 (水平仕様) No Brake (Horizontal Type)	750	220	MHMD082G1U	MCDHT3520
		有煞車 (垂直仕様) With Brake (Vertical Type)	750	220	MHMD082G1V	MCDHT3520
台達 Delta	T	無煞車 (水平仕様) No Brake (Horizontal Type)	750	220	ECMA-C20807ES	ASD-B20721-B
		有煞車 (垂直仕様) With Brake (Vertical Type)	750	220	ECMA-C20807FS	ASD-B20721-B

## 馬達直結 / 馬達外露

Motor Hidden In / Motor Exposed

### BC 馬達直結 Motor Hidden In



Download CAD data at [www.toyorobot.com](http://www.toyorobot.com)

單位 Unit : mm

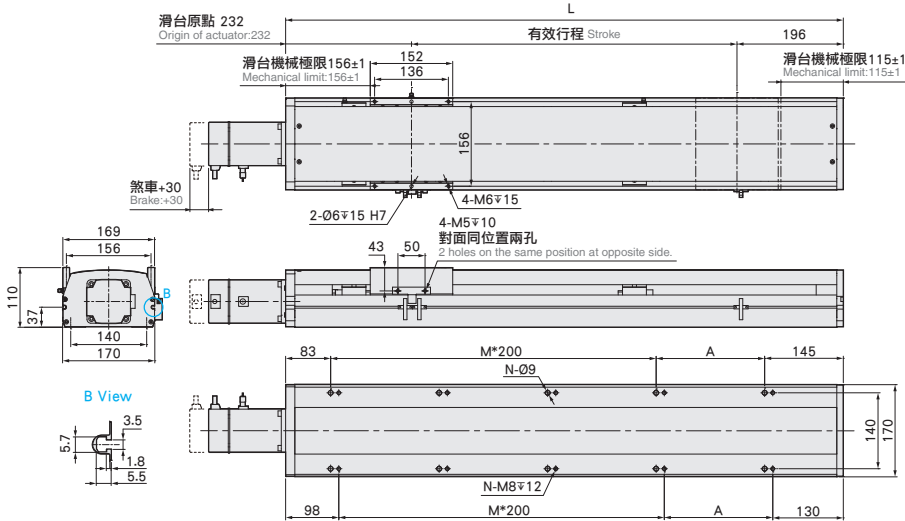

有效行程 Stroke	800	850	900	950	1000	1050	1100	1150	1200	1250	1300	1350	1400	1450	1500	1550	1600	1650	1700	1750	1800	1850	1900	1950	2000	2050	2100	2150	2200
L	1228	1278	1328	1378	1428	1478	1528	1578	1628	1678	1728	1778	1828	1878	1928	1978	2028	2078	2128	2178	2228	2278	2328	2378	2428	2478	2528	2578	2628
A	200	50	100	150	200	50	100	150	200	50	100	150	200	50	100	150	200	50	100	150	200	50	100	150	200	50	100	150	200
M	4	5	5	5	5	6	6	6	6	7	7	7	7	8	8	8	8	9	9	9	9	9	10	10	10	10	11	11	11
N	12	14	14	14	14	16	16	16	16	18	18	18	18	20	20	20	22	22	22	22	22	24	24	24	24	26	26	26	26
KG	29.74	30.42	31.1	31.78	32.46	33.14	33.82	34.5	35.18	35.86	36.54	37.22	37.9	38.58	39.26	39.94	40.62	41.3	41.98	42.66	43.34	44.02	44.7	45.38	46.06	46.74	47.42	48.1	48.78

### BM 馬達下折 Motor Bottom Side



Download CAD data at [www.toyorobot.com](http://www.toyorobot.com)

單位 Unit : mm

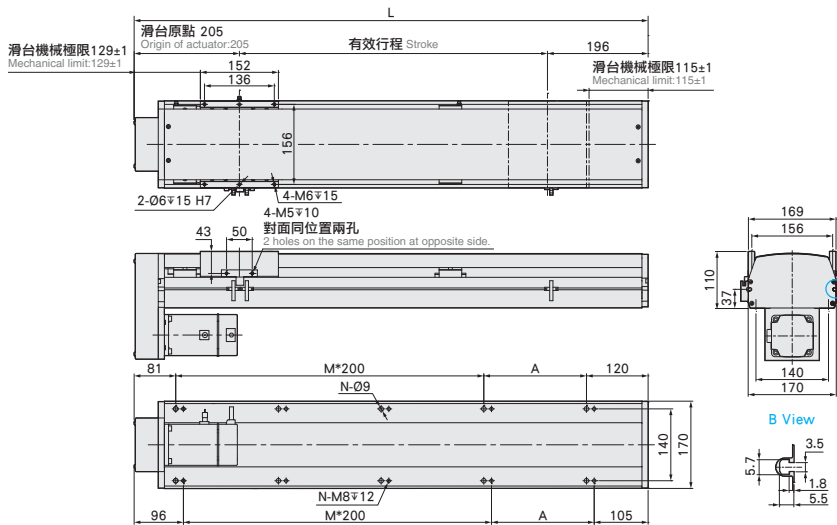

有效行程 Stroke	800	850	900	950	1000	1050	1100	1150	1200	1250	1300	1350	1400	1450	1500	1550	1600	1650	1700	1750	1800	1850	1900	1950	2000	2050	2100	2150	2200
L	1201	1251	1301	1351	1401	1451	1501	1551	1601	1651	1701	1751	1801	1851	1901	1951	2001	2051	2101	2151	2201	2251	2301	2351	2401	2451	2501	2551	2601
A	200	50	100	150	200	50	100	150	200	50	100	150	200	50	100	150	200	50	100	150	200	50	100	150	200	50	100	150	200
M	4	5	5	5	5	6	6	6	6	7	7	7	7	8	8	8	8	9	9	9	9	9	10	10	10	10	11	11	11
N	12	14	14	14	14	16	16	16	16	18	18	18	18	20	20	20	20	22	22	22	22	22	24	24	24	24	26	26	26
KG	30.61	31.29	31.97	32.65	33.33	34.01	34.69	35.37	36.05	36.73	37.41	38.09	38.77	39.45	40.13	40.81	41.49	42.17	42.85	43.53	44.21	44.89	45.57	46.25	46.93	47.61	48.29	48.97	49.65

# 馬達左折 / 馬達右折

## Motor Left Side / Motor Right Side

### BL 馬達左折 Motor Left Side



Download CAD data at [www.toyorobot.com](http://www.toyorobot.com)

單位 Unit : mm

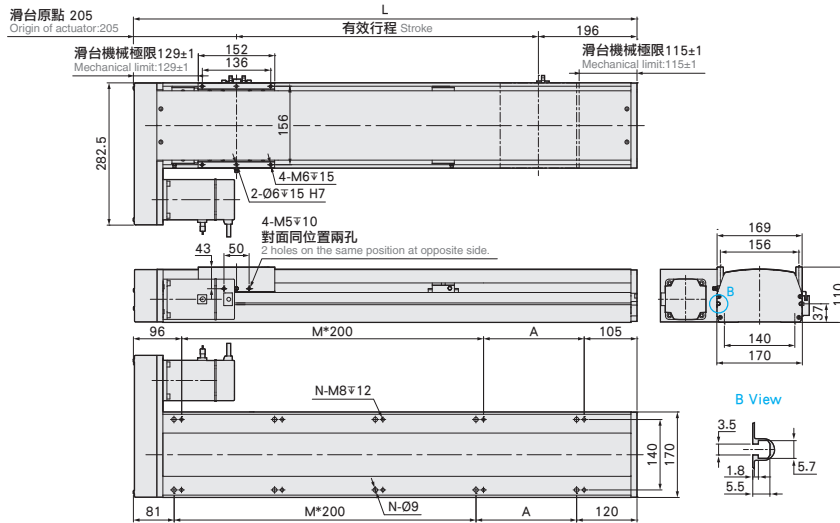

有效行程 Stroke	800	850	900	950	1000	1050	1100	1150	1200	1250	1300	1350	1400	1450	1500	1550	1600	1650	1700	1750	1800	1850	1900	1950	2000	2050	2100	2150	2200
L	1201	1251	1301	1351	1401	1451	1501	1551	1601	1651	1701	1751	1801	1851	1901	1951	2001	2051	2101	2151	2201	2251	2301	2351	2401	2451	2501	2551	2601
A	200	50	100	150	200	50	100	150	200	50	100	150	200	50	100	150	200	50	100	150	200	50	100	150	200	50	100	150	200
M	4	5	5	5	5	6	6	6	6	7	7	7	7	8	8	8	8	9	9	9	9	10	10	10	10	11	11	11	11
N	12	14	14	14	14	16	16	16	16	18	18	18	18	18	20	20	20	22	22	22	22	24	24	24	24	26	26	26	26
KG	30.61	31.29	31.97	32.65	33.33	34.01	34.69	35.37	36.05	36.73	37.41	38.09	38.77	39.45	40.13	40.81	41.49	42.17	42.85	43.53	44.21	44.89	45.57	46.25	46.93	47.61	48.29	48.97	49.65

### BR 馬達右折 Motor Right Side



Download CAD data at [www.toyorobot.com](http://www.toyorobot.com)

單位 Unit : mm

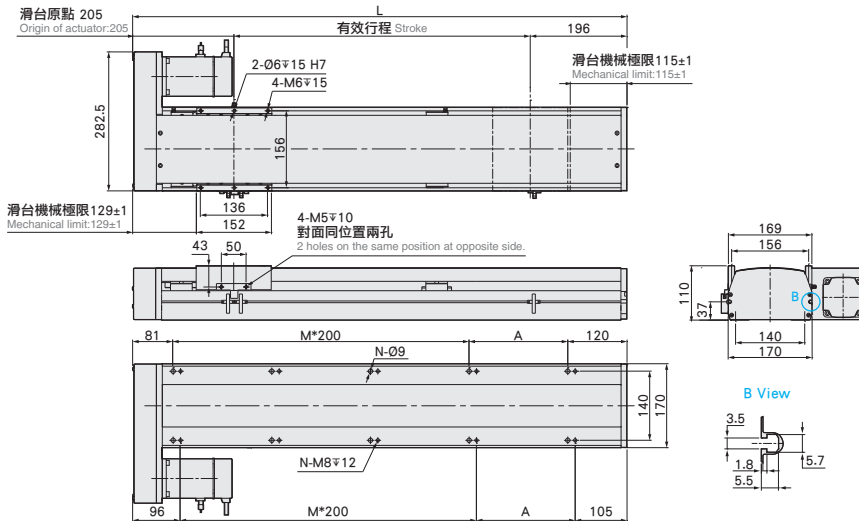

有效行程 Stroke	800	850	900	950	1000	1050	1100	1150	1200	1250	1300	1350	1400	1450	1500	1550	1600	1650	1700	1750	1800	1850	1900	1950	2000	2050	2100	2150	2200
L	1201	1251	1301	1351	1401	1451	1501	1551	1601	1651	1701	1751	1801	1851	1901	1951	2001	2051	2101	2151	2201	2251	2301	2351	2401	2451	2501	2551	2601
A	200	50	100	150	200	50	100	150	200	50	100	150	200	50	100	150	200	50	100	150	200	50	100	150	200	50	100	150	200
M	4	5	5	5	5	6	6	6	6	7	7	7	7	8	8	8	8	9	9	9	9	10	10	10	10	11	11	11	11
N	12	14	14	14	14	16	16	16	16	18	18	18	18	18	20	20	20	22	22	22	22	24	24	24	24	26	26	26	26
KG	30.61	31.29	31.97	32.65	33.33	34.01	34.69	35.37	36.05	36.73	37.41	38.09	38.77	39.45	40.13	40.81	41.49	42.17	42.85	43.53	44.21	44.89	45.57	46.25	46.93	47.61	48.29	48.97	49.65

- 應用例 Application
- 一般 / 螺桿仕樣 ETH Series
- 一般 / 皮帶仕樣 ETB / M
- 無塵 / 螺桿仕樣 GCH / ECH
- 無塵 / 皮帶仕樣 ECB
- 直交連結 XYGT / XYTH / XYTB
- 參考資料 Reference

- 單軸 1 axis ETH
- ETH13
- ETH14
- ETH17
- ETH22
- ETH17M
- ETH22M

# ETH22M 單軸 / 1-axis

▶ 長行程 ▶ 螺桿驅動  
Long Stroke ▶ Ball Screw Drive

精度  
±0.005 mm



◎可對應無塵規格。  
Customizable for clean room type.

此圖僅供參考，出貨規格詳見尺寸圖面  
The picture is just for the reference. Please check the actual dimensions on the drawing.

最大行程  
Maximum Stroke 2400mm

最高速度  
Maximum Speed 1600mm/s

馬達容量  
Motor output 750W

滾珠螺桿  
Ball Screw Ø20mm

直線滑軌  
Linear Guide 20X15-2 支

※ 馬達最高轉速：2400rpm  
※ Maximum motor speed: 2400rpm.

## 型號表示方式 Ordering Method

# ETH22M - L10 - 850 - M - M75B - C4 - 0001

本體型號  
Model

特注式樣  
Special Order No.

行程  
Stroke  
850-2400mm  
50間隔 50 mm Pitch

馬達位置  
Motor Position

M	馬達直結 Motor Hidden In
BC	馬達外露 Motor Exposed
BL	馬達左折 Motor Left Side
BR	馬達右折 Motor Right Side
BM	馬達下折 Motor Bottom Side

馬達廠牌  
Motor Brand

M	三菱 Mitsubishi	10	-	B
P	國際 Panasonic	20	-	
Y	安川 Yaskawa	40	-	
T	台達 Delta	75	750W	

\*若無煞車則不表示。\*If No Brake, No Description.

原點感應器  
Home Sensor

外掛型 Out Side	
C	馬達側 Motor Side
D	反馬達側 Opposite Motor Side
無 SENSOR No Sensor	
E	無 SENSOR No Sensor

端點極限感應器  
Limit Sensor

外掛型 Out Side	
3	1只 1 Pc
4	2只 2 Pc
無 SENSOR No Sensor	
5	無 SENSOR No Sensor

螺桿導程  
Ball Screw Lead

5	5mm
10	10mm
20	20mm
40	40mm

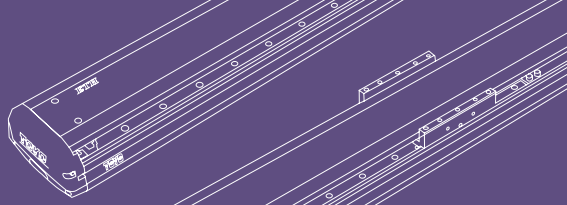

**基本仕様 Specification**

規格 Spec	位置重複精度 Repeatability (mm)	±0.005				
	螺桿導程 Ball Screw Lead (mm)	5	10	20	40	
	最高速度 Maximum Speed (mm/s) ※1	200	400	800	1600	
	最大可搬重量 Maximum Payload	水平使用 Horizontal (kg)	130	130	85	43
		垂直使用 Vertical (kg)	50	40	25	12
	定格推力 Rated Thrust (N)	2563	1281	640	320	
標準行程 Stroke Pitch (mm) ※2	850-2400mm/50 間隔 50 mm Pitch					
部品 Parts	AC 伺服馬達容量 AC Servo Motor Output (W) ※3	750				
	滾珠螺桿外徑 Ball Screw Ø (mm)	C7Ø20				
	高剛性直線滑軌, High Rigidity Linear Guide (mm)	W20XH15				
	連軸器 Coupling (mm)	12X19				
	原點感應器 Home Sensor	外掛 Outside	EE-SX672(NPN)			

※1 馬達加減速設定 0.2 秒。  
Acceleration and deceleration value is set 0.2 second.  
※2 行程超過 2050 時，會產生螺桿偏擺，此時請將速度調降。  
When the stroke is over 2050mm, the run-out of the ballscrew will occur. We recommend to low down the working speed under this circumstances.  
※3 馬達最高轉速：2400rpm。Maximum motor speed: 2400rpm.

**容許負載力距表 Allowable Overhang**

(單位 Unit: mm)	(單位 Unit: mm)	(單位 Unit: mm)																																																																																																																																															
<table border="1"> <thead> <tr> <th>水平安裝 Horizontal Installation</th> <th>A</th> <th>B</th> <th>C</th> </tr> </thead> <tbody> <tr> <td>導程 5 Lead</td> <td>80kg</td> <td>3311</td> <td>411 403</td> </tr> <tr> <td></td> <td>100kg</td> <td>2534</td> <td>320 308</td> </tr> <tr> <td></td> <td>130kg</td> <td>2113</td> <td>228 221</td> </tr> <tr> <td>導程 10 Lead</td> <td>70kg</td> <td>2700</td> <td>430 394</td> </tr> <tr> <td></td> <td>90kg</td> <td>2022</td> <td>320 294</td> </tr> <tr> <td></td> <td>130kg</td> <td>1311</td> <td>198 184</td> </tr> <tr> <td>導程 20 Lead</td> <td>40kg</td> <td>2044</td> <td>662 558</td> </tr> <tr> <td></td> <td>60kg</td> <td>1316</td> <td>417 352</td> </tr> <tr> <td></td> <td>85kg</td> <td>886</td> <td>272 231</td> </tr> <tr> <td>導程 40 Lead</td> <td>20kg</td> <td>1180</td> <td>766 533</td> </tr> <tr> <td></td> <td>25kg</td> <td>927</td> <td>599 418</td> </tr> <tr> <td></td> <td>43kg</td> <td>510</td> <td>318 224</td> </tr> </tbody> </table>	水平安裝 Horizontal Installation	A	B	C	導程 5 Lead	80kg	3311	411 403		100kg	2534	320 308		130kg	2113	228 221	導程 10 Lead	70kg	2700	430 394		90kg	2022	320 294		130kg	1311	198 184	導程 20 Lead	40kg	2044	662 558		60kg	1316	417 352		85kg	886	272 231	導程 40 Lead	20kg	1180	766 533		25kg	927	599 418		43kg	510	318 224	<table border="1"> <thead> <tr> <th>壁掛安裝 Wall Installation</th> <th>A</th> <th>B</th> <th>C</th> </tr> </thead> <tbody> <tr> <td>導程 5 Lead</td> <td>85kg</td> <td>370</td> <td>388 3066</td> </tr> <tr> <td></td> <td>105kg</td> <td>288</td> <td>299 2389</td> </tr> <tr> <td></td> <td>130kg</td> <td>221</td> <td>228 2113</td> </tr> <tr> <td>導程 10 Lead</td> <td>75kg</td> <td>368</td> <td>398 2515</td> </tr> <tr> <td></td> <td>95kg</td> <td>277</td> <td>300 1926</td> </tr> <tr> <td></td> <td>130kg</td> <td>184</td> <td>198 1328</td> </tr> <tr> <td>導程 20 Lead</td> <td>45kg</td> <td>490</td> <td>582 1805</td> </tr> <tr> <td></td> <td>65kg</td> <td>321</td> <td>381 1204</td> </tr> <tr> <td></td> <td>85kg</td> <td>231</td> <td>272 886</td> </tr> <tr> <td>導程 40 Lead</td> <td>25kg</td> <td>418</td> <td>601 930</td> </tr> <tr> <td></td> <td>35kg</td> <td>286</td> <td>408 644</td> </tr> <tr> <td></td> <td>43kg</td> <td>224</td> <td>318 510</td> </tr> </tbody> </table>	壁掛安裝 Wall Installation	A	B	C	導程 5 Lead	85kg	370	388 3066		105kg	288	299 2389		130kg	221	228 2113	導程 10 Lead	75kg	368	398 2515		95kg	277	300 1926		130kg	184	198 1328	導程 20 Lead	45kg	490	582 1805		65kg	321	381 1204		85kg	231	272 886	導程 40 Lead	25kg	418	601 930		35kg	286	408 644		43kg	224	318 510	<table border="1"> <thead> <tr> <th>垂直安裝 Vertical Installation</th> <th>A</th> <th>C</th> </tr> </thead> <tbody> <tr> <td>導程 5 Lead</td> <td>30kg</td> <td>1301 1301</td> </tr> <tr> <td></td> <td>40kg</td> <td>977 977</td> </tr> <tr> <td></td> <td>50kg</td> <td>781 781</td> </tr> <tr> <td>導程 10 Lead</td> <td>20kg</td> <td>1735 1735</td> </tr> <tr> <td></td> <td>30kg</td> <td>1156 1156</td> </tr> <tr> <td></td> <td>40kg</td> <td>867 867</td> </tr> <tr> <td>導程 20 Lead</td> <td>15kg</td> <td>1835 1835</td> </tr> <tr> <td></td> <td>20kg</td> <td>1376 1376</td> </tr> <tr> <td></td> <td>25kg</td> <td>1101 1101</td> </tr> <tr> <td>導程 40 Lead</td> <td>7kg</td> <td>1943 1943</td> </tr> <tr> <td></td> <td>12kg</td> <td>1133 1133</td> </tr> <tr> <td></td> <td>-</td> <td>- -</td> </tr> </tbody> </table>	垂直安裝 Vertical Installation	A	C	導程 5 Lead	30kg	1301 1301		40kg	977 977		50kg	781 781	導程 10 Lead	20kg	1735 1735		30kg	1156 1156		40kg	867 867	導程 20 Lead	15kg	1835 1835		20kg	1376 1376		25kg	1101 1101	導程 40 Lead	7kg	1943 1943		12kg	1133 1133		-	- -
水平安裝 Horizontal Installation	A	B	C																																																																																																																																														
導程 5 Lead	80kg	3311	411 403																																																																																																																																														
	100kg	2534	320 308																																																																																																																																														
	130kg	2113	228 221																																																																																																																																														
導程 10 Lead	70kg	2700	430 394																																																																																																																																														
	90kg	2022	320 294																																																																																																																																														
	130kg	1311	198 184																																																																																																																																														
導程 20 Lead	40kg	2044	662 558																																																																																																																																														
	60kg	1316	417 352																																																																																																																																														
	85kg	886	272 231																																																																																																																																														
導程 40 Lead	20kg	1180	766 533																																																																																																																																														
	25kg	927	599 418																																																																																																																																														
	43kg	510	318 224																																																																																																																																														
壁掛安裝 Wall Installation	A	B	C																																																																																																																																														
導程 5 Lead	85kg	370	388 3066																																																																																																																																														
	105kg	288	299 2389																																																																																																																																														
	130kg	221	228 2113																																																																																																																																														
導程 10 Lead	75kg	368	398 2515																																																																																																																																														
	95kg	277	300 1926																																																																																																																																														
	130kg	184	198 1328																																																																																																																																														
導程 20 Lead	45kg	490	582 1805																																																																																																																																														
	65kg	321	381 1204																																																																																																																																														
	85kg	231	272 886																																																																																																																																														
導程 40 Lead	25kg	418	601 930																																																																																																																																														
	35kg	286	408 644																																																																																																																																														
	43kg	224	318 510																																																																																																																																														
垂直安裝 Vertical Installation	A	C																																																																																																																																															
導程 5 Lead	30kg	1301 1301																																																																																																																																															
	40kg	977 977																																																																																																																																															
	50kg	781 781																																																																																																																																															
導程 10 Lead	20kg	1735 1735																																																																																																																																															
	30kg	1156 1156																																																																																																																																															
	40kg	867 867																																																																																																																																															
導程 20 Lead	15kg	1835 1835																																																																																																																																															
	20kg	1376 1376																																																																																																																																															
	25kg	1101 1101																																																																																																																																															
導程 40 Lead	7kg	1943 1943																																																																																																																																															
	12kg	1133 1133																																																																																																																																															
	-	- -																																																																																																																																															

**靜態容許負載價量 Static Loading Moment**

(單位 Unit: N.m)						
<table border="1"> <thead> <tr> <th>MY</th> <th>MP</th> <th>MR</th> </tr> </thead> <tbody> <tr> <td>1254</td> <td>1254</td> <td>1254</td> </tr> </tbody> </table>	MY	MP	MR	1254	1254	1254
MY	MP	MR				
1254	1254	1254				

\* 力距表所表示的數據，代表重心。  
The torque value in the chart indicate the center of gravity.  
\* 符合型錄規範的正常使用下，保證壽命為 10000 公里。  
Operation life is 10,000km when the product is using under the specified conditions.  
\* 倒吊使用無法套用標準規範，如有需求請洽詢我司業務。  
Data information is not for ceiling-mount inverse use.  
Contact us for the details if you want to apply ceiling-mount inverse usage.

**搭配伺服馬達一覽表 Suitable Motor Brand**

廠牌 Brand	馬達記號 Mark	煞車有無 Brake	馬達容量 Watt	電源電壓 AC-Voltage	伺服馬達型號 Motor Model	驅動器型號 Driver Model
三菱 Mitsubishi	M	無煞車 (水平仕様) No Brake (Horizontal Type)	750	220	HG-KR73	MR-J4-70A
		有煞車 (垂直仕様) With Brake (Vertical Type)	750	220	HG-KR73B	MR-J4-70A
國際 Panasonic	P	無煞車 (水平仕様) No Brake (Horizontal Type)	750	220	MHMD082G1U	MCDHT3520
		有煞車 (垂直仕様) With Brake (Vertical Type)	750	220	MHMD082G1V	MCDHT3520
台達 Delta	T	無煞車 (水平仕様) No Brake (Horizontal Type)	750	220	ECMA-C20807ES	ASD-B20721-B
		有煞車 (垂直仕様) With Brake (Vertical Type)	750	220	ECMA-C20807FS	ASD-B20721-B

# ETH22M 單軸 / 1axis

▶ 長行程 ▶ 螺桿驅動  
Long Stroke ▶ Ball Screw Drive

## 馬達直結 / 馬達外露

Motor Hidden In / Motor Exposed

### M 馬達直結 Motor Hidden In



Download CAD data at [www.toyorobot.com](http://www.toyorobot.com)

單位 Unit : mm

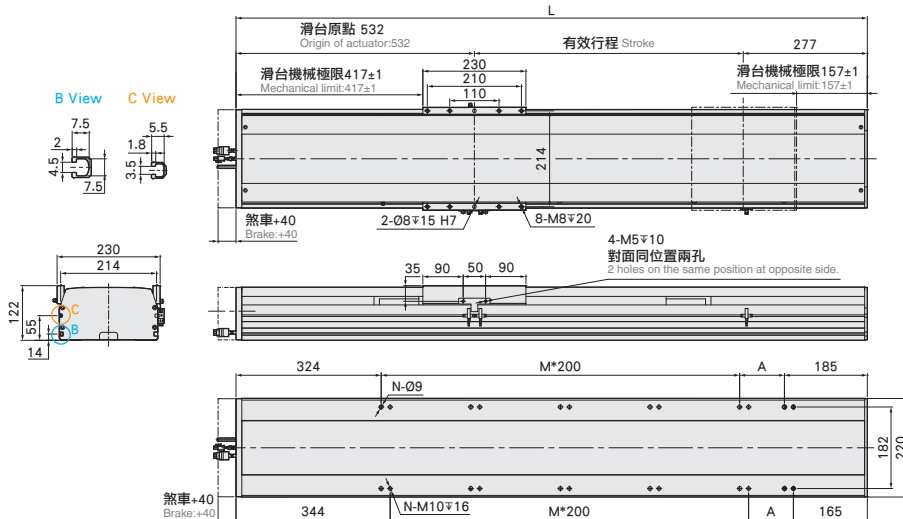

有效行程 Stroke	850	900	950	1000	1050	1100	1150	1200	1250	1300	1350	1400	1450	1500	1550	1600	1650	1700	1750	1800	1850	1900	1950	2000	2050	2100	2150	2200	2250	2300	2350	2400
L	1659	1709	1759	1809	1859	1909	1959	2009	2059	2109	2159	2209	2259	2309	2359	2409	2459	2509	2559	2609	2659	2709	2759	2809	2859	2909	2959	3009	3059	3109	3159	3209
A	150	200	50	100	150	200	50	100	150	200	50	100	150	200	50	100	150	200	50	100	150	200	50	100	150	200	50	100	150	200	50	100
M	5	5	6	6	6	6	7	7	7	7	8	8	8	8	9	9	9	9	10	10	10	10	11	11	11	11	12	12	12	12	13	13
N	14	14	16	16	16	16	18	18	18	18	20	20	20	20	22	22	22	22	24	24	24	24	26	26	26	26	28	28	28	28	30	30
KG	56.61	57.97	59.33	60.69	62.05	63.41	64.77	66.13	67.49	68.85	70.21	71.57	72.93	74.29	75.65	77.01	78.37	79.73	81.09	82.45	83.81	85.17	86.53	87.89	89.25	90.61	91.97	93.33	94.69	96.05	97.41	98.77

### BC 馬達外露 Motor Exposed



Download CAD data at [www.toyorobot.com](http://www.toyorobot.com)

單位 Unit : mm

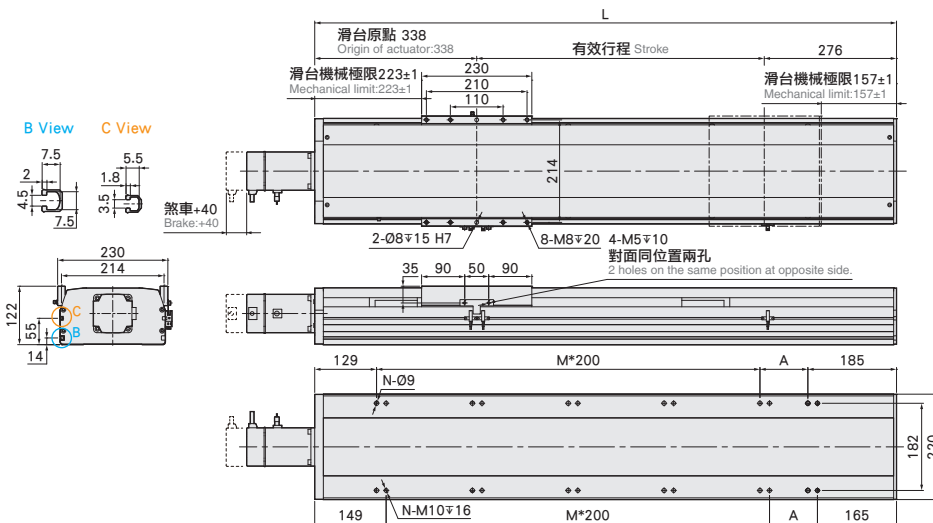

有效行程 Stroke	850	900	950	1000	1050	1100	1150	1200	1250	1300	1350	1400	1450	1500	1550	1600	1650	1700	1750	1800	1850	1900	1950	2000	2050	2100	2150	2200	2250	2300	2350	2400
L	1464	1514	1564	1614	1664	1714	1764	1814	1864	1914	1964	2014	2064	2114	2164	2214	2264	2314	2364	2414	2464	2514	2564	2614	2664	2714	2764	2814	2864	2914	2964	3014
A	150	200	50	100	150	200	50	100	150	200	50	100	150	200	50	100	150	200	50	100	150	200	50	100	150	200	50	100	150	200	50	100
M	5	5	6	6	6	6	7	7	7	7	8	8	8	8	9	9	9	9	10	10	10	10	11	11	11	11	12	12	12	12	13	13
N	14	14	16	16	16	16	18	18	18	18	20	20	20	20	22	22	22	22	24	24	24	24	26	26	26	26	28	28	28	28	30	30
KG	53.91	55.27	56.63	57.99	59.35	60.71	62.07	63.43	64.79	66.15	67.51	68.87	70.23	71.59	72.95	74.31	75.67	77.03	78.39	79.75	81.11	82.47	83.83	85.19	86.55	87.91	89.27	90.63	91.99	93.35	94.71	96.07



# 馬達左折 / 馬達右折

## Motor Left Side / Motor Right Side

### BL 馬達左折 Motor Left Side



Download CAD data at [www.toyorobot.com](http://www.toyorobot.com)

單位 Unit : mm

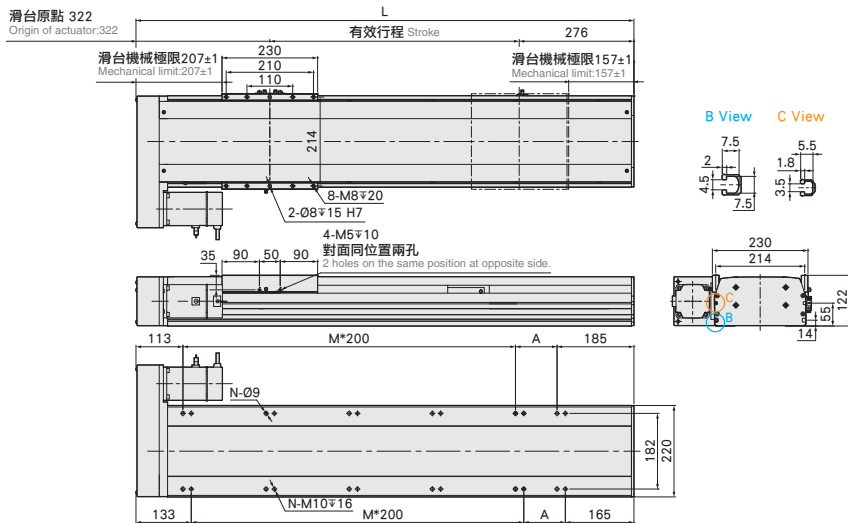

有效行程 Stroke	850	900	950	1000	1050	1100	1150	1200	1250	1300	1350	1400	1450	1500	1550	1600	1650	1700	1750	1800	1850	1900	1950	2000	2050	2100	2150	2200	2250	2300	2350	2400
L	1448	1498	1548	1598	1648	1698	1748	1798	1848	1898	1948	1998	2048	2098	2148	2198	2248	2298	2348	2398	2448	2498	2548	2598	2648	2698	2748	2798	2848	2898	2948	2998
A	150	200	50	100	150	200	50	100	150	200	50	100	150	200	50	100	150	200	50	100	150	200	50	100	150	200	50	100	150	200	50	100
M	5	5	6	6	6	6	7	7	7	7	8	8	8	8	9	9	9	9	10	10	10	10	11	11	11	11	12	12	12	12	13	13
N	14	14	16	16	16	16	18	18	18	18	20	20	20	22	22	22	22	24	24	24	24	24	26	26	26	26	28	28	28	28	30	30
KG	55.11	56.47	57.83	59.19	60.55	61.91	63.27	64.63	65.99	67.35	68.71	70.07	71.43	72.79	74.15	75.51	76.87	78.23	79.59	80.95	82.31	83.67	85.03	86.39	87.75	89.11	90.47	91.83	93.19	94.55	95.91	97.27

### BR 馬達右折 Motor Right Side



Download CAD data at [www.toyorobot.com](http://www.toyorobot.com)

單位 Unit : mm

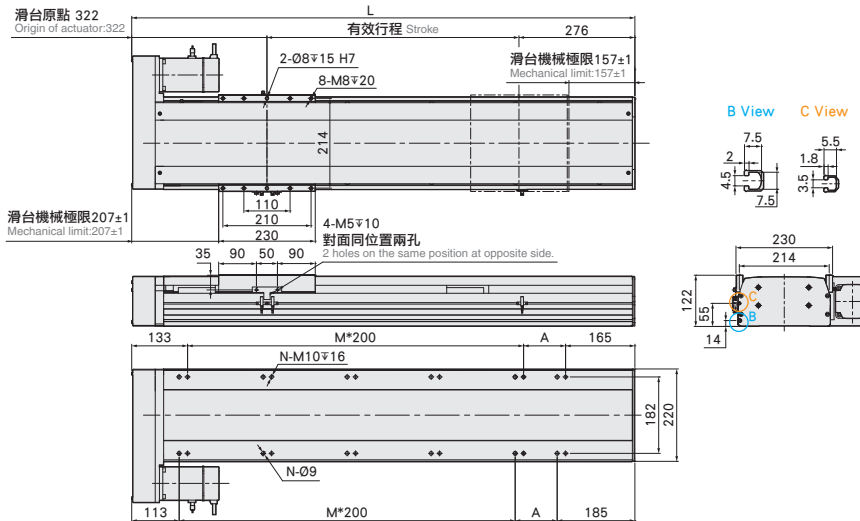

有效行程 Stroke	850	900	950	1000	1050	1100	1150	1200	1250	1300	1350	1400	1450	1500	1550	1600	1650	1700	1750	1800	1850	1900	1950	2000	2050	2100	2150	2200	2250	2300	2350	2400	
L	1448	1498	1548	1598	1648	1698	1748	1798	1848	1898	1948	1998	2048	2098	2148	2198	2248	2298	2348	2398	2448	2498	2548	2598	2648	2698	2748	2798	2848	2898	2948	2998	
A	150	200	50	100	150	200	50	100	150	200	50	100	150	200	50	100	150	200	50	100	150	200	50	100	150	200	50	100	150	200	50	100	
M	5	5	6	6	6	6	7	7	7	7	8	8	8	8	9	9	9	9	10	10	10	10	10	11	11	11	11	12	12	12	12	13	13
N	14	14	16	16	16	16	18	18	18	18	20	20	20	22	22	22	22	22	24	24	24	24	24	26	26	26	26	28	28	28	28	30	30
KG	55.11	56.47	57.83	59.19	60.55	61.91	63.27	64.63	65.99	67.35	68.71	70.07	71.43	72.79	74.15	75.51	76.87	78.23	79.59	80.95	82.31	83.67	85.03	86.39	87.75	89.11	90.47	91.83	93.19	94.55	95.91	97.27	

應用例  
Application  
一般 / 螺桿仕様  
ETH Series  
一般 / 皮帶仕様  
ETB / M  
無塵 / 螺桿仕様  
GCH / ECH  
無塵 / 皮帶仕様  
ECB  
直交連結  
XYGT / XYTH / XYTB  
參考資料  
Reference

單軸  
1 axis  
ETH  
ETH13  
ETH14  
ETH17  
ETH22  
ETH17M  
ETH22M

## 馬達下折

### Motor Bottom Side

單位 Unit : mm

BM 馬達下折 Motor Bottom Side   [Download CAD data at www.toyorobot.com](http://www.toyorobot.com)

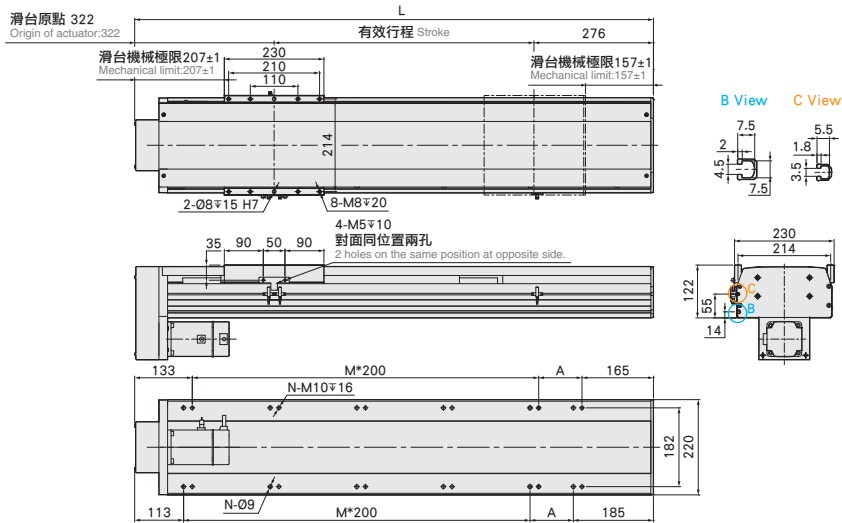

有效行程 Stroke	850	900	950	1000	1050	1100	1150	1200	1250	1300	1350	1400	1450	1500	1550	1600	1650	1700	1750	1800	1850	1900	1950	2000	2050	2100	2150	2200	2250	2300	2350	2400
L	1448	1498	1548	1598	1648	1698	1748	1798	1848	1898	1948	1998	2048	2098	2148	2198	2248	2298	2348	2398	2448	2498	2548	2598	2648	2698	2748	2798	2848	2898	2948	2998
A	150	200	50	100	150	200	50	100	150	200	50	100	150	200	50	100	150	200	50	100	150	200	50	100	150	200	50	100	150	200	50	100
M	5	5	6	6	6	6	7	7	7	7	8	8	8	8	9	9	9	9	10	10	10	10	11	11	11	11	12	12	12	12	13	13
N	14	14	16	16	16	16	18	18	18	18	20	20	20	20	22	22	22	22	24	24	24	24	26	26	26	26	28	28	28	28	30	30
KG	55.11	56.47	57.83	59.19	60.55	61.91	63.27	64.63	65.99	67.35	68.71	70.07	71.43	72.79	74.15	75.51	76.87	78.23	79.59	80.95	82.31	83.67	85.03	86.39	87.75	89.11	90.47	91.83	93.19	94.55	95.91	97.27