

DMG40

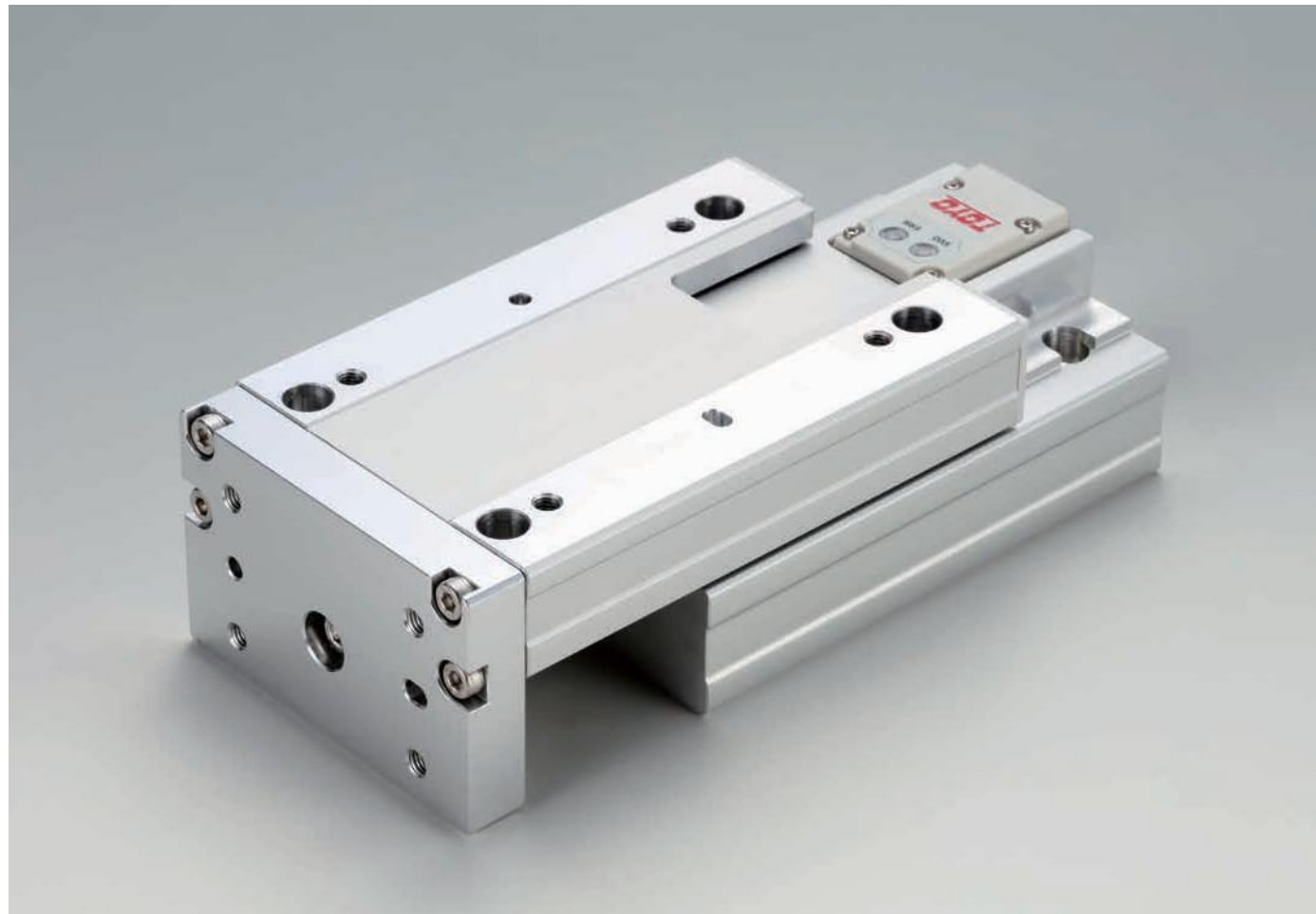

螺桿驅動 Ball Screw Drive

免費服務專線：大陸 400-875-0009 台灣 0800-800-893
Toll-Free Number China 400-875-0009 Taiwan 0800-800-893



最大行程 Maximum Stroke 100mm 最高速度 Maximum Speed 200mm/s 馬達容量 Motor Dimers 40W 滾珠螺桿 Ball Screw \varnothing 10mm

型號表示方式 Ordering Method

DMG40 - L2 -100 - XC100 - 03 - N1 -A001

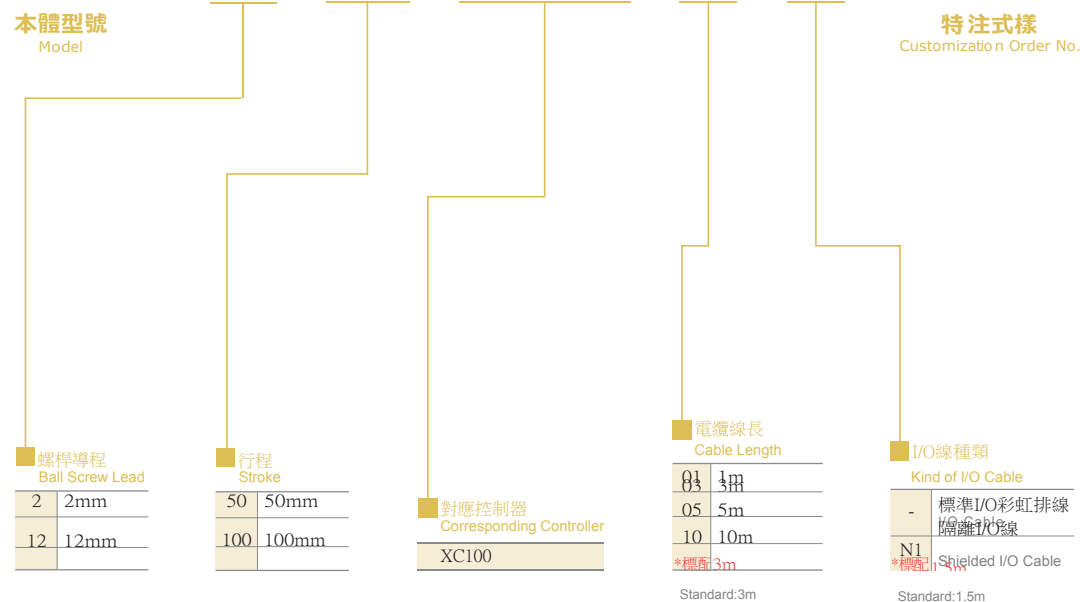

基本仕様 Specification

Spec		±0.02			
		2	6	12	
	最高速度 Maximum Speed (mm/s)*1	33.3	100	200	
	最大可搬重量 Maximum Payload (kg)		15	9	6
			4	3	2
			427	142	71
Parts	滾珠螺桿規格 Ball Screw Spec	50 / 75 / 100			
		40			
		C7 \varnothing 10mm			

*1 此處最高速度為軟體移動速度設定為100%時。
The maximum speed shown here is when software speed setting is 100%.

靜態容許負載慣量 Static Loading Moment

For horizontal use (Unit: N.m)

MY	9
MP	9
MR	33.2

※符合型錄規範的正常情況下，保證壽命為5000萬次。
Operation life is 50 million times when the product is using under the specified conditions.

對應控制器一覽表 Corresponding Controller Chart

外觀 Exterior	控制器型號 Controller Model	控制介面 Control Mode	特點 Features	電氣規格 Electrical Spec.	詳細參閱 Reference Page
	XC100	Pulse控制	Lin driver 200k Hz Open collector 60k Hz 同時只能使用一種。 Support Line driver and Open collector Max pulse receiving speed 200k/60k Hz.	控制電路只能使用24V 額定 電壓DC24V， 電流3A 峰值電流8A。 The voltage of control circuit is 24V only. Operating voltage DC24V, rated current 3A, peak current 8A.	P.167
		I/O控制 I/O Control Mode	利用I/O變化，最多可以執行127個 位置控制。 By I/O control, max. 127 positioning points, can be executed.		
		通訊控制 Communication Control Mode	採Modbus的RS485通訊介面 最大並接16台及一組mini USB (TOYO-Single專用)。 Use Modbus as the interface of RS485 (connect max. 16 controllers) and 1 set mini USB. (special for TOYO-single)		

DMG40



螺桿驅動 Ball Screw Drive

免費樣品索取：大陸 400-875-0009 台灣 0800-800-893
Tel-Free Member 2019

2D CAD 3D CAD
CAD圖面可至 www.toyorobot.com 下載
Please download the CAD file from TOYO's website: www.toyorobot.com

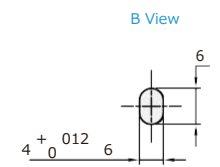
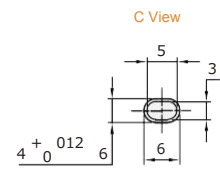
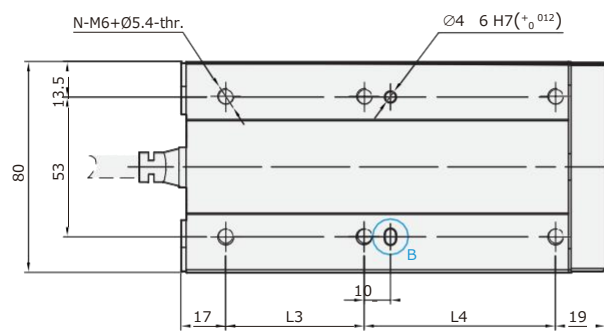
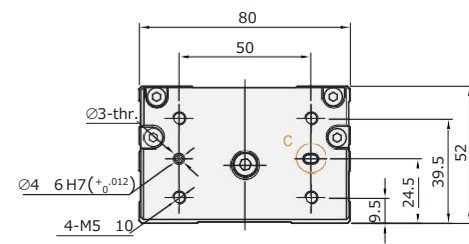
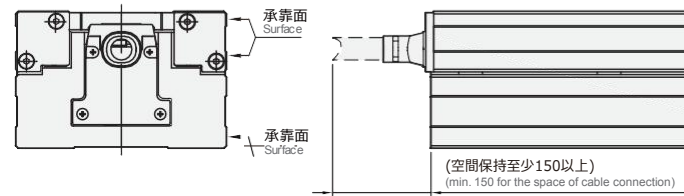
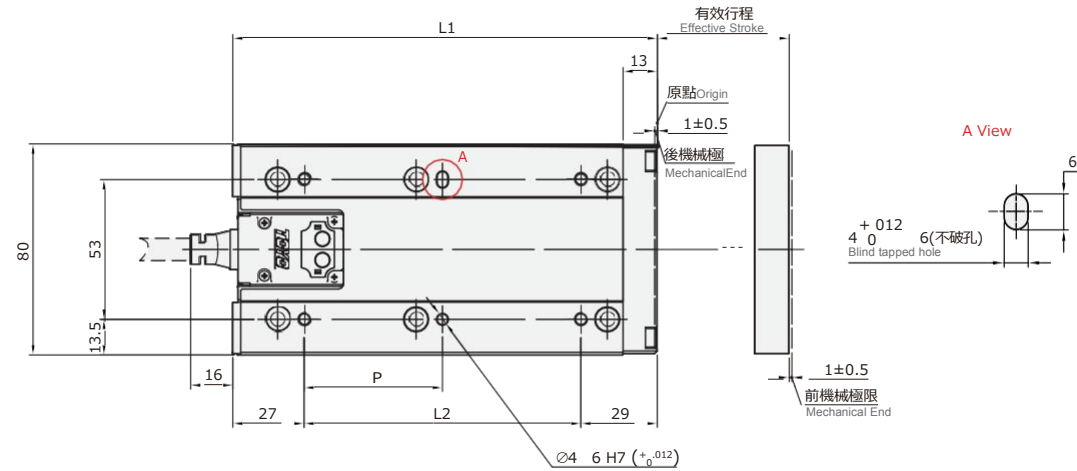

	136	80	0	100	40	4	1530
	161	105	52.5	72.5	52.5	6	1750
	186	130	65	85	65	6	1930

*重量包含本體與馬達 *Weight of model with motor.

Memo