

CHY2-S150



連桿式電動夾爪 Shaft Drive

免費服務專線：大陸 400-875-0009 台灣 0800-800-893
Toll-Free Number China 400-875-0009 Taiwan 0800-800-893



馬達尺寸 Motor Dimension 35□mm

型號表示方式 Ordering Method

CHY2 - S150 - 15

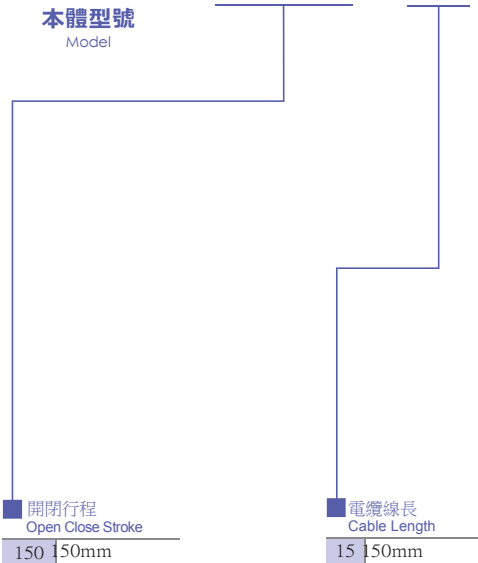

基本仕様 Specification

Spec	夾持重量 Weight (kg)	4.5
	夾持力範圍 Gripping force (N)	12~45 (30~100%)
	開閉行程 Open and close stroke (mm)※1	150
	開閉速度 Open and close speed (mm/s)	40~200
	位置重複精度 Position repeatability (mm)	±0.05 連桿機構
	導引機構 Guide structure	hafts
	使用溫度範圍 Operating temperature range (°C)	0~+40 以下(無結露)
Parts	使用濕度範圍 Operating humidity range (%)	RH90 Below RH90 Dew free
	馬達尺寸 Motor Dimension (mm)	35□
重量 Weight (g)※2	890	

※1 雙邊合計行程・Total stroke of both sides.
※2 重量包含本體與馬達・Weight of model with motor.

夾持力與指令值曲線表 Gripping Power vs. Gripping Power Setting (%)

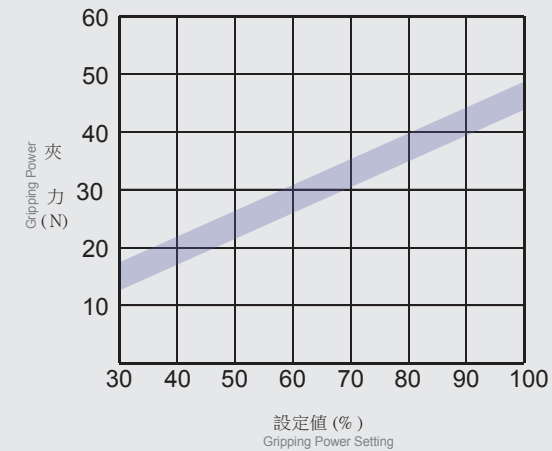

*夾持力誤差:±15% +/-15% clamping force tolerance .

特色說明 DM Series DGT Series DGT Series DGT Series CS Series CGTH Series CGTH Series CGTH Series CH Series 連桿式電動夾爪

- CH
- CHS-S20
- CHS-S40
- CHS-S68
- CHY2-S80
- CHY2-S150**
- CHB6-S11
- CHB6-S14
- CHG2
- CHZ20
- CHZ25

CHY2-S150



連桿式電動夾爪 Shaft Drive

免費技術專線：大陸 400-875-0009 台灣 0800-800-893
Toll-Free Number: 400-875-0009 Taiwan 0800-800-893

S150 標準型 Standard Type
2D CAD 3D CAD
CAD圖面可至www.toyorobot.com下載
Please download the CAD file from TOYO's website: www.toyorobot.com

(單位 Unit : mm)

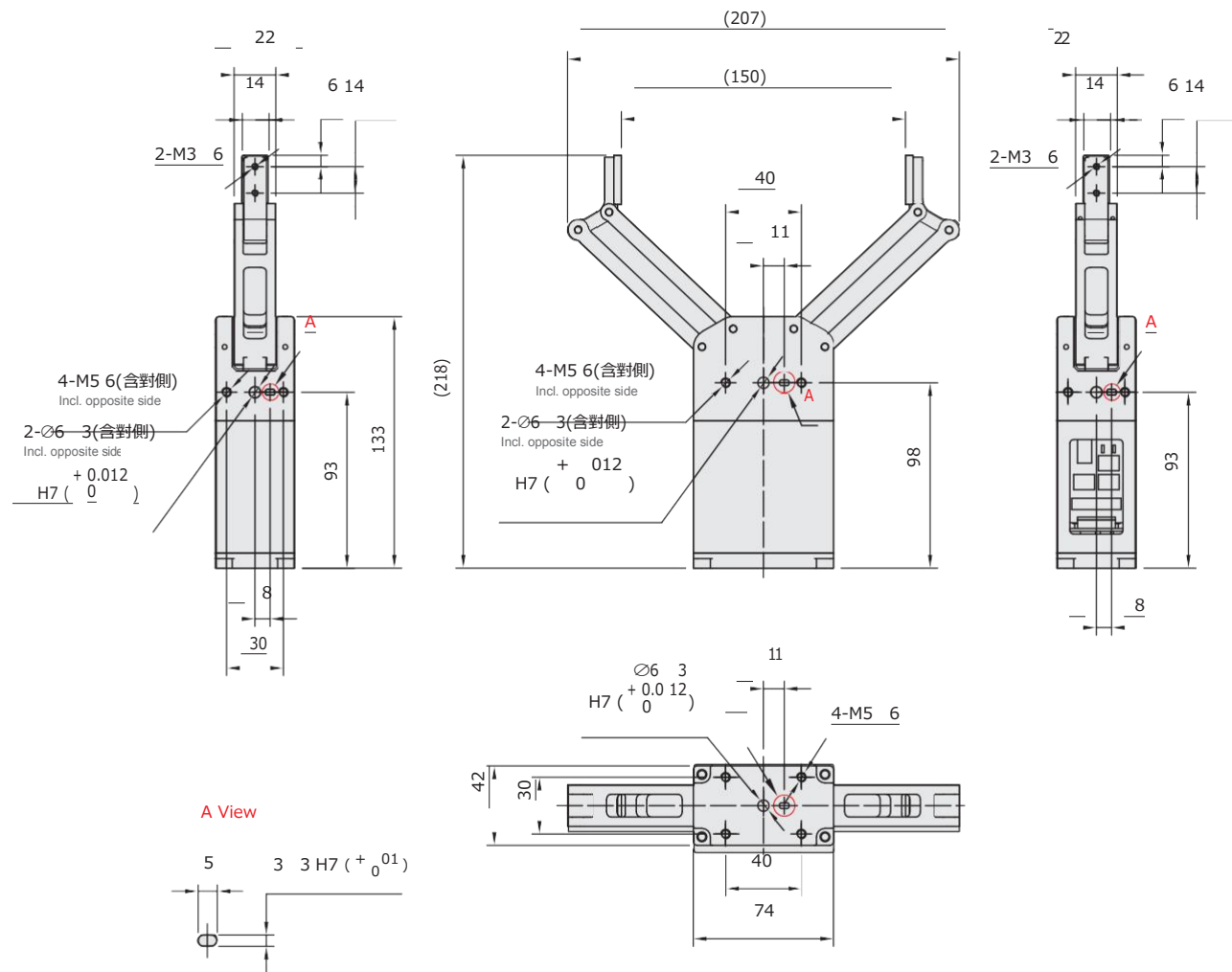

Memo