

CHS2-S40



螺桿驅動 Ball Screw Drive

免費維修專線：大陸 400-875-0009 台灣 0800-800-893



馬達尺寸 25□mm
Motor Dimension

型號表示方式 Ordering Method

CHS2 - S40 - TC100 - 03 - N1 - W - A001

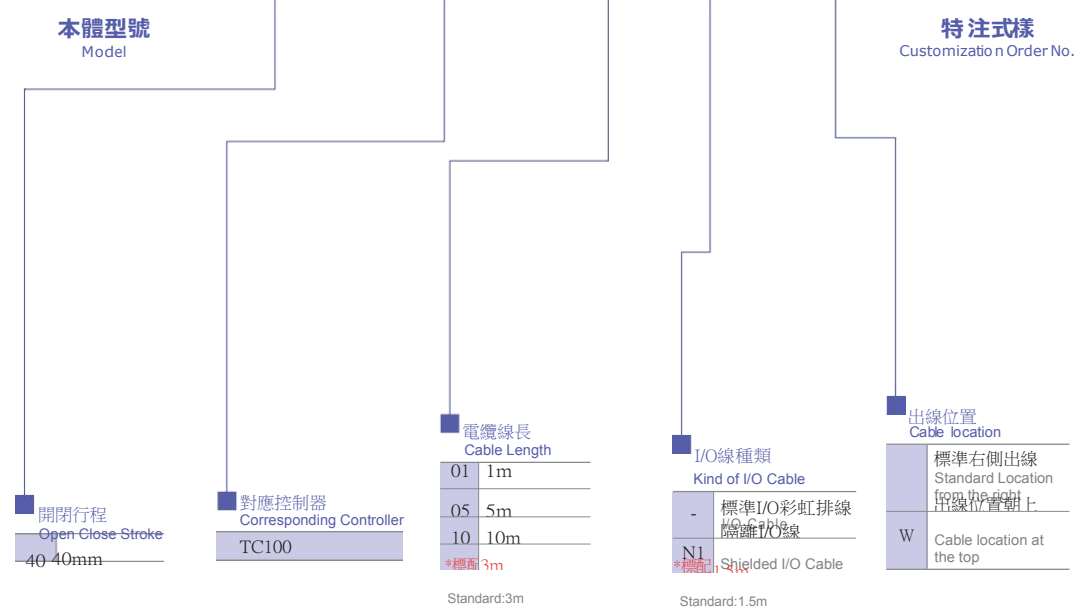

基本仕様 Specification

規格 Spec	夾持重量 Weight (kg)	2.58
	夾持力範圍 Gripping force (N)	40~258 (15~100%)
	開閉行程 Ball Screw Lead (mm)	40
	開閉速度 Open/Close Speed (mm/s)	8.2~41
	位置重複精度 Position repeatability (mm)	±0.01
	導引機構 Guide structure	線性滑軌 Linear guide
	使用溫度範圍 Operating temperature range (°C)	0~+40 以下(無結露)
部品 Parts	馬達尺寸 Motor Dimension (mm)	25 □
	重量 Weight (g)※1	625

※1 重量包含本體與馬達。 Weight of model with motor.

夾持力與指令值曲線表 Gripping Power vs. Gripping Power Setting (%)

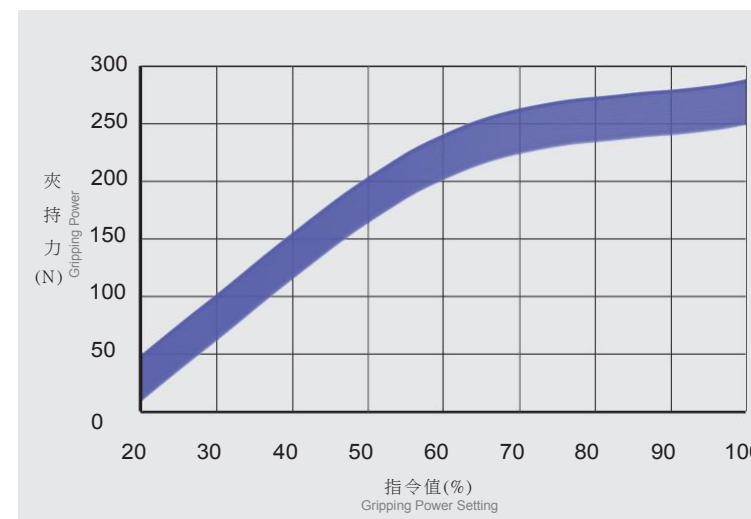

*夾持力誤差:±15% +/-15% clamping force tolerance.

容許夾持負載力矩表 Allowable Moment

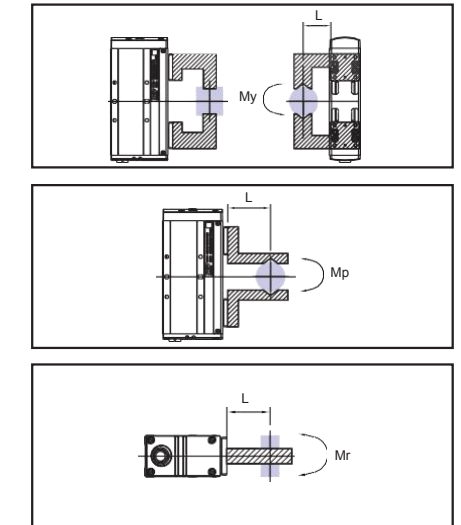

*L:夾爪至負荷作用點之距離(mm)
Distance to the loading location (單位 Unit:N.m)

偏力矩 Allowable yawing moment	最大容許力矩 MY maximum moment	13.74
俯仰力矩 Allowable pitching moment	MP	13.74
滾動力矩 Allowable rolling moment	MR	37.08

*表中負荷及力矩的值表示靜的值
The value in the chart is static, not dynamic loading and torque.

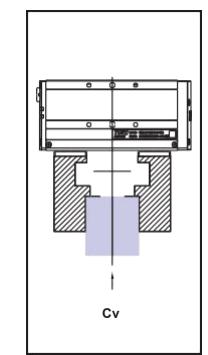

垂直方向容許靜負荷 FV
Vertical Maximum Force
4120.4

對應控制器一覽表 Corresponding Controller Chart

外觀 Exterior	控制器型號 Controller Model	控制介面 Control Mode	特點 Features	電氣規格 Electrical Spec.	詳細參閱 Reference Page
	TC100	I/O控制 I/O Control Mode	利用I/O變化,最多可以執行127個位置控制。 By I/O control, max. 127 positioning points, can be executed.	控制電路只能使用24V 額定 工作 壓DC24V, 額定 電流 2A 峰值電流3A。額定 工作 壓DC48V, 電流 1A 峰值電流2A。 使用DC48V時在相同扭力下, 轉速會提升。詳細內容請跟服務 窗口連結。 The voltage of control circuit is 24V only. Operating voltage DC24V, rated current 2A, peak current 3A. Operating voltage DC48V, rated current 1A, peak current 2A. When the voltage is DC48V but same torque, the rotation speed will be raised. Please contact your service window to details.	P.175
		通訊控制 Communication Control Mode	採Modbus的RS485通訊介面 (最大並接16台)及一組mini USB (TOYO-Single專用)。 Use Modbus as the interface of RS485 (connect max. 16 controllers) and 1 set mini USB. (special for TOYO-Single)		

CHS2-S40



螺桿驅動 Ball Screw Drive

免費維修專線：大陸 400-875-0009 台灣 0800-800-893
Toll-Free Number: 400-875-0009 Taiwan 0800-800-893

2D CAD 3D CAD
CAD圖面可至www.toyorobot.com下載
Please download the CAD file from TOYO's website: www.toyorobot.com

(單位 Unit : mm)

Memo

